



OWNER'S MANUAL

TRAM TRAILERS





Thank You... From Featherlite Trailers

Dear Customer,

Thank you for purchasing a Featherlite Trailer.

You are now part of tens of thousands in North America who enjoy Featherlite Trailers for their premium grade construction, innovative features and custom interiors. Featherlite builds hundreds of different standard and custom-designed aluminum specialty trailers and transporters. For each and every one, customer satisfaction is Featherlite's passion and safety is top priority.

Featherlite knows the most important thing that goes into each and every trailer is what you, our customer, put in it. That is why the features of all Featherlite trailers are engineered with the customer and the cargo in mind.

Please know that Featherlite's dedicated dealers and employees are here for you. Let Featherlite know how we can be of service now and in the future.

Thanks again and best wishes!

Featherlite Trailers

P.S. Keep current on Featherlite's innovative new trailers at www.fthr.com.

THANK YOU FOR CHOOSING FEATHERLITE!

Table of Contents
TRAM TRAILERS

1	SAFETY INFORMATION.....	1			
1.1	SAFETY ALERT SYMBOLS AND SIGNAL WORDS	1			
1.2	MAJOR HAZARDS.....	1			
1.2.1	<i>Improper Sizing of the Trailer to the Tow Vehicle.</i>	1			
1.2.2	<i>Driving Too Fast</i>	2			
1.2.3	<i>Failure to Adjust Driving Behavior When Towing a Trailer</i>	2			
1.2.4	<i>Improper Loading</i>	2			
1.2.5	<i>Trailer Not Properly Coupled to the Hitch</i>	3			
1.2.6	<i>Proper Use of Safety Chains</i>	3			
1.2.7	<i>Proper Connection of Breakaway Brake</i>	3			
1.2.8	<i>Matching Trailer and Hitch</i>	4			
1.2.9	<i>Worn Tires, Loose Wheels and Lug Nuts</i>	4			
1.2.10	<i>Weight And Load Distribution</i>	5			
1.2.11	<i>Intended Use</i>	5			
1.2.12	<i>Inoperable Brakes, Lights or Mirrors</i>	5			
1.2.13	<i>Hazards From Modifying Your Trailer</i>	5			
1.2.14	<i>Trailer Towing Guide</i>	5			
1.2.15	<i>Safe Trailer Towing Guidelines</i>	6			
1.2.16	<i>Safety Warning Labels on Your Trailer</i>	7			
1.2.18	<i>Reporting Safety Defects</i>	7			
2	TIRE SAFETY INFORMATION.....	8			
2.1	TRAILER TIRE INFORMATION	8			
2.2	STEPS FOR DETERMINING CORRECT LOAD LIMIT – TRAILER.....	9			
2.2.1	<i>Trailers 10,000 Pounds GVWR or Less</i>	10			
2.2.2	<i>Trailers Over 10,000 Pounds GVWR</i>	10			
2.3	STEPS FOR DETERMINING CORRECT LOAD LIMIT – TOW VEHICLE.....	10			
2.4	GLOSSARY OF TIRE TERMINOLOGY	10			
2.5	TIRE SAFETY - EVERYTHING RIDES ON IT.....	13			
2.5.1	<i>Safety First–Basic Tire Maintenance</i>	14			
2.5.2	<i>Finding Your Vehicle's Recommended Tire Pressure and Load Limits</i>	14			
2.5.3	<i>Understanding Tire Pressure and Load Limits</i>	14			
2.5.4	<i>Checking Tire Pressure</i>	14			
2.5.5	<i>Steps for Maintaining Proper Tire Pressure</i> ...	15			
2.5.6	<i>Tire Size</i>	15			
2.5.7	<i>Tire Tread</i>	15			
2.5.8	<i>Tire Balance and Wheel Alignment</i>	15			
2.5.9	<i>Tire Repair</i>	15			
2.5.10	<i>Tire Fundamentals</i>	15			
2.5.10.a	<i>Information on Passenger Vehicle Tires</i>	16			
2.5.10.b	<i>UTQGS Information</i>	16			
2.5.10.c	<i>Information on Light Truck (LT) Tires</i>	17			
2.5.10.d	<i>Information on Special Trailer (ST) Tires</i>	17			
2.5.11	<i>Tire Safety Tips</i>	18			
3	COUPLING TO THE TOW VEHICLE	19			
3.1	USE AN ADEQUATE TOW VEHICLE AND HITCH	19			
3.1.1	<i>Trailer Information</i>	19			
3.1.2	<i>Tow Vehicle</i>	20			
3.2	COUPLING AND UNCOUPLING THE TRAILER	21			
3.2.1	<i>Ball Hitch Coupler</i>	22			
			3.2.1.a	<i>Before Coupling Trailer to Tow Vehicle</i>	22
			3.2.1.b	<i>Prepare the Coupler and Hitch</i>	22
			3.2.1.c	<i>Couple Trailer to Tow Vehicle</i>	23
			3.2.1.d	<i>Rig Safety Chains</i>	23
			3.2.1.e	<i>Attach and Test Breakaway Brake System</i>	24
			3.2.1.f	<i>Connect Electrical Cables</i>	25
			3.2.2	<i>Connect Rear/Second Trailer</i>	25
			3.2.3	<i>Uncoupling Trailers</i>	26
4	LOADING PASSENGERS	27			
4.1	TONGUE WEIGHT	27			
4.2	LOADING PASSENGERS	27			
5	CHECKING THE TRAILER BEFORE AND DURING EACH TOW	29			
5.1	PRE-TOW CHECKLIST	29			
5.2	MAKE REGULAR STOPS	29			
6	BREAKING-IN A NEW TRAILER.....	30			
6.1	RETIGHTEN LUG NUTS AT FIRST 10, 25 & 50 MILES	30			
6.2	ADJUST BRAKE SHOES AT FIRST 200 MILES	30			
6.3	SYNCHRONIZING THE BRAKE SYSTEMS	30			
6.4	TIRE PRESSURE	30			
7	ACCESSORIES	31			
7.1	WHEELCHAIR RAMP	31			
7.1.1	<i>Install Ramp</i>	31			
7.1.2	<i>Remove and Stow Ramp</i>	32			
8	INSPECTION, SERVICE & MAINTENANCE	33			
8.1	INSPECTION, SERVICE & MAINTENANCE SUMMARY CHARTS	33			
8.2	INSPECTION AND SERVICE INSTRUCTIONS	34			
8.2.1	<i>Axle Bolts, Frame, Suspension, & Structure</i>	34			
8.2.2	<i>Trailer Structure</i>	34			
8.2.2.a	<i>Fasteners and Frame Members</i>	34			
8.2.2.b	<i>Welds</i>	35			
8.2.3	<i>Trailer Brakes</i>	35			
8.2.3.a	<i>Initial Inspection</i>	35			
8.2.3.b	<i>Periodic Inspection</i>	35			
8.2.3.c	<i>Manually Adjusting Brake Shoes</i>	35			
8.2.3.d	<i>Electric Brakes</i>	36			
8.2.4	<i>Trailer Hitch Coupler</i>	36			
8.2.5	<i>Landing Leg or Jack</i>	37			
8.2.6	<i>Lights and Signals</i>	37			
8.2.7	<i>Tires</i>	37			
8.2.8	<i>Wheel Rims</i>	37			
8.2.9	<i>Wheel Bearings</i>	37			
8.2.9.a	<i>Nev-R-Lube™ or Other Sealed Bearings</i>	37			
8.2.10	<i>Lug Nuts (Bolts)</i>	37			
9	TECHNICAL REFERENCE.....	40			
9.1	TRAILER LIGHTING ELECTRICAL CONNECTION	40			
9.2	HITCH SYSTEMS	41			



WARNING

This User's Manual contains safety information and instructions for your trailer.

You must read this manual before loading or towing your trailer.

You must follow all safety precautions and instructions.

"Portions of this manual were used with the expressed authority of Dexter Axle, but Dexter Axle is not responsible for the accuracy of the information contained herein."

1 SAFETY INFORMATION

1.1 SAFETY ALERT SYMBOLS AND SIGNAL WORDS

This manual provides instructions for the operation and care of Featherlite Tram Trailers. The instructions in this manual must be followed to ensure the safety of persons and satisfactory life of the trailer. Safety precautions to protect against injury or property damage must be followed at all times.

An Owner's Manual that provides general trailer information cannot cover all of the specific details necessary for the proper combination of every trailer, tow vehicle and hitch. Therefore, you must read, understand and follow the instructions given by the tow vehicle and trailer hitch manufacturers, as well as the instructions in this manual.

Our trailers are built with components produced by various manufacturers. Some of these items have separate instruction manuals. Where this manual indicates that you should read another manual, and you do not have that manual, call Featherlite, Inc. at 800-800-1230.

The safety information in this manual is denoted by the safety alert symbol: 

The level of risk is indicated by the following signal words.

 DANGER
DANGER – Immediate hazards which WILL result in severe personal injury or death if the warning is ignored.

 WARNING
WARNING – Hazards or unsafe practices which COULD result in severe personal injury or death if the warning is ignored.

 CAUTION
CAUTION – Hazards or unsafe practices which could result in minor or moderate injury if the warning is ignored.

NOTICE
NOTICE – Practices that could result in damage to the trailer or other property.

1.2 MAJOR HAZARDS

Loss of control of the trailer or trailer/tow vehicle combination can result in death or serious injury. The most common causes for loss of control of the trailer are:

- Improper sizing the trailer for the tow vehicle, or vice versa.
- Excessive Speed: Driving too fast for the conditions.
- Failure to adjust driving behavior when towing a trailer.
- Overloading and/or improper weight distribution.
- Improper or mis-coupling of the trailer to the hitch.
- Improper braking and steering under sway conditions.
- Not maintaining proper tire pressure.
- Not keeping lug nuts tight.

1.2.1 Improper Sizing of the Trailer to the Tow Vehicle.

Trailers that weigh too much for the towing vehicle can cause stability problems, which can lead to death or serious injury. Furthermore, the additional strain put on the engine and drive-train may lead to serious tow vehicle maintenance problems. For these reasons the maximum towing capacity of your towing vehicle should not be exceeded. The towing capacity of your tow vehicle, in terms of maximum Gross Trailer Weight (GTW) and maximum Gross Combined Weight Rating (GCWR) can be found in the tow vehicles Owner's Manual.

Section 1 - Safety Information

DANGER

Use of an under-rated hitch, ball or tow vehicle can result in loss of control leading to death or serious injury.

Make certain your hitch and tow vehicle are rated for your trailer.

1.2.2 Driving Too Fast

With ideal road conditions, the maximum recommended speed for safely towing a trailer on a road is 60 mph. If you drive too fast, the trailer is more likely to sway, thus increasing the possibility for loss of control. Also your tires may overheat, thus increasing the possibility of a blowout.

Maximum speed while transporting passengers is 15 mph. Do not transport passenger on a public road.

WARNING

Driving too fast for conditions can result in loss of control and cause death or serious injury.

Adjust speed down when towing trailer.

1.2.3 Failure to Adjust Driving Behavior When Towing a Trailer

When towing a trailer, you will have decreased acceleration, increased stopping distance, and increased turning radius (which means you must make wider turns to keep from hitting curbs, vehicles, and anything else that is on the inside corner). Furthermore, the trailer will change the handling characteristics of your towing vehicle, making it more sensitive to steering inputs and more likely to be pushed around in windy conditions or when being passed by large vehicles. In addition, you will need a longer distance to pass, due to slower acceleration and increased length. With this in mind:

- Be alert for slippery conditions. You are more likely to be affected by slippery road surfaces when driving a tow vehicle with a trailer, than driving a tow vehicle without a trailer.

- Anticipate the trailer “swaying.” Swaying can be caused by excessive steering, wind gusts, roadway edges, or by the trailer reaction to the pressure wave created by passing trucks and busses.
- When encountering trailer sway, take your foot off the accelerator, and steer as little as possible in order to stay on the road. Use small “trim-like” steering adjustments. Do not attempt to steer out of the sway; you’ll only make it worse. Also, do not apply the tow vehicle brakes to correct trailer swaying. The application of the trailer brakes alone will tend to straighten out the combination, especially when going downhill.
- Check rearview mirrors frequently to observe the trailer and traffic.
- Use lower gear when driving down steep or long grades. Use the engine and transmission as a brake. Do not ride the brakes, as they can overheat and become ineffective.
- Be aware of your trailer height, especially when approaching bridges, roofed areas and around trees.

1.2.4 Improper Loading

The total weight of the passengers, plus the empty weight of the trailer itself, must not exceed the trailer's Gross Vehicle Weight Rating (GVWR). The empty weight of the trailer is approximately 3200 lbs. The GVWR and GAWR's are listed on the Certification / VIN label mounted on the front left side of the trailer. The maximum number of people that can be transported on a trailer is 28.

WARNING

An overloaded trailer can result in failure or in loss of control of the trailer, leading to death or serious injury.

Never load a trailer so that the weight on any tire exceeds its rating.

Never exceed the trailer Gross Vehicle Weight Rating (GVWR).

Never exceed an axle Gross Axle Weight Rating (GAWR).

Section 1 - Safety Information

1.2.5 Trailer Not Properly Coupled to the Hitch

It is critical that the trailer be securely coupled to the hitch, and that the safety chains and emergency breakaway brake lanyard are correctly attached. Uncoupling may result in death or serious injury to you and to others.

WARNING

Coupler and hitch selection and condition are critical for safe towing.

Uncoupling can result in death or serious injury.

- **Make sure the hitch and ball are rated for the trailer.**
- **Make sure the hitch [ball size] matches the coupler.**
- **Check the hitch ball for wear, corrosion and cracks before coupling. Replace worn, corroded or cracked hitch ball before coupling to the trailer.**
- **Make sure the hitch ball is tight to the hitch before coupling the trailer.**

WARNING

An improperly coupled trailer can result in death or serious injury.

Do not move the trailer until:

- **The coupler is secured and locked;**
- **The safety chains are secured to the tow vehicle; and**
- **The trailer jack is fully retracted.**

Do not tow the trailer until:

- **The trailer brakes are checked;**
- **The breakaway switch is connected to the tow vehicle;**
- **The trailer lights are connected and checked.**

1.2.6 Proper Use of Safety Chains

Safety chains are provided so that control of the trailer can still be maintained if the trailer comes loose from the tow vehicle for any reason.

WARNING

Incorrect rigging of the safety chains can result in loss of control of the trailer and tow vehicle, leading to death or serious injury, if the trailer uncouples from the tow vehicle.

Chains must:

- **Fasten to frame of tow vehicle, not to hitch or ball.**
- **Cross underneath hitch and coupler with minimum slack to permit turning and to hold tongue up, if the trailer comes loose.**

1.2.7 Proper Connection of Breakaway Brake

Your trailer is equipped with a breakaway brake system that can apply the brakes on your trailer, if your trailer comes loose from the hitch for any reason. You will have a separate set of instructions for the breakaway brake. The breakaway brake system, including battery, must be in good condition and properly rigged to be effective.

WARNING

An ineffective breakaway brake system can result in a runaway trailer, leading to death or serious injury if the coupler or ball hitch fails.

Test the function of the breakaway brake system before towing the trailer. Do not tow the trailer if the breakaway brake system is not working; have it serviced or repaired.

Connect the breakaway lanyard to the tow vehicle -

NOT to the safety chain; and

NOT to the hitch, ball or support.

Section 1 - Safety Information

1.2.8 Matching Trailer and Hitch

DANGER

Use of an under-rated hitch, ball or tow vehicle can result in loss of control leading to death or serious injury.

Make certain your hitch and tow vehicle are rated for your trailer.

1.2.9 Worn Tires, Loose Wheels and Lug Nuts

Just as with your tow vehicle, the trailer tires and wheels are important safety items. Therefore, it is essential to inspect the trailer tires before each tow.

If a tire has a bald spot, bulge, cut, cracks, or is showing any cords, replace the tire before towing. If a tire has uneven tread wear, take the trailer to a dealer service center for diagnosis. Uneven tread wear can be caused by tire imbalance, axle misalignment or incorrect inflation.

Tires with too little tread will not provide adequate frictional forces on wet roadways and can result in loss of control, leading to death or serious injury.

Improper tire pressure causes increased tire wear and may reduce trailer stability, which can result in a tire blowout or possible loss of control. Therefore, before each tow you must also check the tire pressure. Remember, the proper tire pressure is listed on the Certification (VIN) label, and should be checked when tires are cold. Allow 3 hours cool-down after driving as much as 1 mile at 40 mph before checking tire pressure.

WARNING

Improper tire pressure may cause an unstable trailer. Blowout and loss of control may occur. Death or serious injury can result.

Make sure of proper tire pressure before towing trailer. Inflate tires to pressure indicated on the Certification / VIN label.

The tightness of the lug nuts is very important in keeping the wheels properly seated to the hub.

Before each tow, check to make sure they are tightened to the proper torque.

WARNING

Metal creep between the wheel rim and lug nuts (bolts) will cause rim to loosen.

Death or injury can occur if wheel comes off.

Tighten lug nuts (bolts) before each tow.

The proper tightening sequence and tightness (torque) for lug nuts is listed in the “Inspection, Service & Maintenance” chapter of this manual. Use a calibrated torque wrench to tighten the lug nuts.

Lug nuts are also prone to loosen after first being assembled. When driving a new trailer (or after wheels have been remounted), check to make sure they are tightened to the proper torque after the **first** 10, 25 and 50 miles of driving and before each tow thereafter.

Failure to perform this check can result in a wheel parting from the trailer and a crash, leading to death or serious injury.

WARNING

Lug nuts are prone to loosen after being first assembled. Death or serious injury can result.

Check lug nuts for tightness on a new trailer, and after re-mounting a wheel at 10, 25 and 50 miles.

WARNING

Inadequate lug nut torque can cause a wheel to part while towing. Death or serious injury can result.

Make sure lug nuts are tight before towing trailer.

Section 1 - Safety Information

1.2.10 Weight And Load Distribution

Proper loading of your trailer is essential for your safety. Tire, wheel, axle or structural failure can be caused by overloading.

⚠ WARNING

An overloaded trailer can result in failure or in loss of control of the trailer, leading to death or serious injury.

Never load a trailer so that the weight on any tire exceeds its rating.

Never exceed the trailer Gross Vehicle Weight Rating (GVWR).

Never exceed an axle Gross Axle Weight Rating (GAWR).

Improper front / rear load distribution can lead to poor trailer sway stability or poor tow vehicle handling. Poor trailer sway stability results from tongue weights that are too low, and poor tow vehicle stability results from tongue weights that are too high.

For example, a trailer with a loaded weight of 4,000 pounds, should have 10-15% of 4,000 pounds (400-600 lbs.) on the hitch. After loading, be sure to check that none of the axles are overloaded.

1.2.11 Intended Use

Your trailer is designed to transport up to 28 people (6600 lbs.) on non-public roads at less than 15 mph. One trailer may be coupled to the first trailer for a total of two tram trailers behind a tow vehicle.

⚠ Do not connect more than two trailers behind a properly rated and equipped tow vehicle.

1.2.12 Inoperable Brakes, Lights or Mirrors

Be sure that the brakes and all of the lights on your trailer are functioning properly before towing your trailer. Electric brakes and lights on a trailer are controlled via a connection to the tow vehicle, generally a multi-pin electrical connector. Check the trailer taillights by turning on your tow vehicle headlights. Check the trailer brake lights by having someone step on the tow vehicle brake pedal while you look at trailer lights. Check the turn signal

lights by operating the turn signal lever in the tow vehicle.

Your tow vehicle will have an electric brake controller that sends power to the trailer brakes. Before towing the trailer, you must operate the brake controller while trying to pull the trailer in order to confirm that the electric brakes operate. While towing the trailer at less than 5 mph, manually operate the electric brake controller in the tow vehicle cab. You should feel the operation of the trailer brakes.

⚠ WARNING

Failure to connect the tow vehicle lighting and braking to the trailer will result in inoperable lights and brakes, and can lead to collision.

Check that all the trailer lights and brakes work before each tow.

Standard mirrors usually do not provide adequate visibility for viewing traffic to the sides and rear a towed trailer. You must provide mirrors that allow you to safely observe approaching traffic.

1.2.13 Hazards From Modifying Your Trailer

Essential safety items and structural integrity can be damaged by altering your trailer.

Before making any alteration to your trailer, contact your dealer or Featherlite, Inc. at 800-800-1230 and describe the alteration you are contemplating. Alteration of the trailer structure or modification of mechanical, electrical or other systems on your trailer must be performed only by qualified technicians who are familiar with the system as installed on your trailer.

1.2.14 Trailer Towing Guide

Driving a vehicle with a trailer in tow is vastly different from driving the same vehicle without a trailer in tow. Acceleration, maneuverability and braking are all diminished with a trailer in tow. It takes longer to get up to speed, you need more room to turn and pass, and more distance to stop when towing a trailer. You will need to spend time adjusting to the different feel and maneuverability of the tow vehicle with a loaded trailer. Because of

Section 1 - Safety Information

the significant differences in all aspects of maneuverability when towing a trailer, the hazards and risks of injury are also much greater than when driving without a trailer. You are responsible for keeping your vehicle and trailer in control, and for all the damage that is caused if you lose control of your vehicle and trailer.

As you did when learning to drive an automobile, find an open area with little or no traffic for your first practice trailering. Of course, before you start towing the trailer, you must follow all of the instructions for inspection, testing, loading and coupling. Also, before you start towing, adjust the mirrors so you can see the trailer as well as the area to the rear of it.

Drive slowly at first, 5 m.p.h. or so, and turn the wheel to get the feel of how the tow vehicle and trailer combination responds. Next, make some right and left hand turns. Watch in your side mirrors to see how the trailer follows the tow vehicle. Turning with a trailer attached requires more room.

Stop the rig a few times from speeds no greater than 10 m.p.h. If your trailer is equipped with brakes, try using different combinations of trailer/electric brake and tow vehicle brake. Note the effect that the trailer brakes have when they are the only brakes used. When properly adjusted, the trailer brakes will come on just before the tow vehicle brakes.

It will take practice to learn how to back up a tow vehicle with a trailer attached. Take it slow. Before backing up, get out of the tow vehicle and look behind the trailer to make sure that there are no obstacles. Some drivers place their hands at the bottom of the steering wheel, and while the tow vehicle is in reverse, “think” of the hands as being on the top of the wheel. When the hands move to the right (counter-clockwise, as you would do to turn the tow vehicle to the left when moving forward), the rear of the trailer moves to the right. Conversely, rotating the steering wheel clockwise with your hands at the bottom of the wheel will move the rear of the trailer to the left, while backing up. If you are towing a bumper hitch rig, be careful not to allow the trailer to turn too much, because it will hit the rear of the tow vehicle. To straighten the rig, either pull forward, or turn the steering wheel in the opposite direction.

1.2.15 Safe Trailer Towing Guidelines

- Before towing, check coupling, safety chain, safety brake, tires, wheels and lights.
- Check the lug nuts or bolts for tightness.
- Check coupler tightness after towing 50 miles.
- Adjust the brake controller to engage the trailer brakes before the tow vehicle brakes. Your dealer can assist you by making this adjustment.
- Use your mirrors to verify that you have room to change lanes or pull into traffic.
- Use your turn signals well in advance.
- Allow plenty of stopping space for your trailer and tow vehicle.
- Do not drive so fast that 15 mph while transporting passengers.
- Allow plenty of room for passing. A rule of thumb is that the passing distance with a trailer is 4 times the passing distance without a trailer.
- Shift your transmission into a lower gear for city driving.
- Use lower gears for climbing and descending grades.
- Do not ride the brakes while descending grades, they may get so hot that they stop working. Then you will potentially have a runaway tow vehicle and trailer.
- Slow down for bumps in the road. Take your foot off the brake when crossing the bump.
- Do not brake while in a curve unless absolutely necessary. Instead, slow down before you enter the curve and power through the curve.
- Do not apply the brakes to correct extreme trailer swaying. The application of the trailer brakes alone will tend to straighten out the combination, especially when going downhill.
- Make regular stops, about once each hour. Confirm that:
 - The coupler is secure to the hitch and is locked,
 - Electrical connectors are made,
 - There is appropriate slack in the safety chains,
 - There is appropriate slack in the breakaway switch pullpin lanyard,
 - Tires are not visibly low on pressure.

Section 1 - Safety Information

1.2.16 Safety Warning Labels on Your Trailer

A - 045334.0000 Certification Label (USA) or 045335.0000 (Canada)

B - 045330.000 NATM guidelines

C - 27747 Wiring Guide

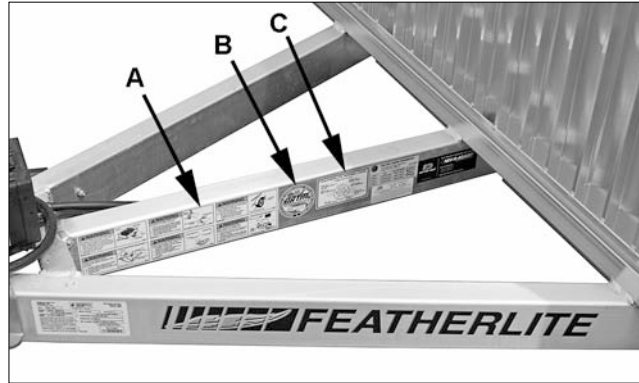

Warning Labels and Locations - Figure 1-1

⚠ WARNING
<p>To protect you and others against death or serious injury, all of the labels shown must be on the trailer and must be legible.</p> <p>If any of these labels are missing or cannot be read, call Featherlite, Inc. at 800-800-1230 for free replacement labels.</p> <p>You will need to provide us with the number shown at the bottom of the label(s) in order for us to send the correct one(s).</p>

1.2.18 Reporting Safety Defects

If you believe that your vehicle has a defect that could cause a crash or could cause injury or death, you should immediately inform the National Highway Traffic Safety Administration (NHTSA) in addition to notifying us.

If NHTSA receives similar complaints, it may open an investigation, and if it finds that a safety defect exists in a group of vehicles, it may order a recall and remedy campaign. However, NHTSA cannot become involved in individual problems between you, your dealer, or us.

To contact NHTSA, you may either call the Vehicle Safety Hotline toll-free at 1-888-327-4236 (TTY: 1-800-424-9153), go to <http://www.safercar.gov>; or write to: Administrator, NHTSA 1200 New Jersey Ave., SE, Washington, DC 20590. You can also

obtain other information about motor vehicle safety from <http://www.safercar.gov>.

Call 800-800-1230 to reach Featherlite, Inc.

2 TIRE SAFETY INFORMATION

This portion of the User's Manual contains tire safety information as required by 49 CFR 575.6.

Section 2.1 contains "Trailer Tire Information"

Section 2.2 contains "Steps for Determining Correct Load Limit - Trailer".

Section 2.3 contains "Steps for Determining Correct Load Limit – Tow Vehicle".

Section 2.4 contains a Glossary of Tire Terminology, including "cold inflation pressure", "maximum inflation pressure", "recommended inflation pressure", and other non-technical terms.

Section 2.5 contains information from the NHTSA brochure entitled "Tire Safety – Everything Rides On It".

This brochure, as well as the preceding subsections, describe the following items;

- Tire labeling, including a description and explanation of each marking on the tires, and information about the DOT Tire Identification Number (TIN).
- Recommended tire inflation pressure, including a description and explanation of:
 - Cold inflation pressure.
 - Vehicle Placard and location on the vehicle.
 - Adverse safety consequences of under inflation (including tire failure).
 - Measuring and adjusting air pressure for proper inflation.
- Tire Care, including maintenance and safety practices.
- Vehicle load limits, including a description and explanation of the following items:
 - Locating and understanding the load limit information, total load capacity, and cargo capacity.
 - Calculating total and cargo capacities with varying seating configurations including quantitative examples showing / illustrating how the vehicles cargo and luggage capacity decreases as combined number and size of occupants' increases. This item is also discussed in Section 3.

- Determining compatibility of tire and vehicle load capabilities.
- Adverse safety consequences of overloading on handling and stopping on tires.

2.1 TRAILER TIRE INFORMATION

Trailer tires may be worn out even though they still have plenty of tread left. This is because trailer tires have to carry a lot of weight all the time, even when not in use. It is actually better for the tire to be rolling down the road than to be idle. During use, the tire releases lubricants that are beneficial to tire life. Using the trailer tires often also helps prevent flat spots from developing.

The main cause of tire failure is improper inflation. Check the cold tire inflation pressures at least once a week for proper inflation levels. "Cold" means that the tires are at the same temperature as the surrounding air, such as when the vehicle has been parked overnight. Wheel and tire manufacturers recommend adjusting the air pressure to the trailer manufacturer's recommended cold inflation pressure, in pounds per square inch (PSI) stated on the vehicle's Federal Certification Label or Tire Placard when the trailer is loaded to its gross vehicle weight rating (GVWR). If the tires are inflated to less than the recommended inflation level or the GVWR of the trailer is exceeded, the load carrying capacity of the tire could be dramatically affected. If the tires are inflated more than the recommended inflation level, handling characteristics of the tow vehicle/trailer combination could be affected. Refer to the owner's manual or talk to your dealer or vehicle manufacturer if you have any questions regarding proper inflation practices.

Tires can lose air over a period of time. In fact, tires can lose 1 to 3 PSI per month. This is because molecules of air, under pressure, weave their way from the inside of the tire, through the rubber, to the outside. A drop in tire pressure could cause the tire to become overloaded, leading to excessive heat buildup. If a trailer tire is under-inflated, even for a short period of time, the tire could suffer internal damage.

Section 2 - Tire Safety Information

High speed towing in hot conditions degrades trailer tires significantly. As heat builds up during driving, the tire's internal structure starts to breakdown, compromising the strength of the tire. It is recommended to drive at moderate speeds.

Statistics indicate the average life of a trailer tire is about five years under normal use and maintenance conditions. After three years, replacing the trailer tires with new ones should be considered, even if the tires have adequate tread depth. Some experts claim that after five years, trailer tires are considered worn out and should be replaced, even if they have had minimal or no use. This is such a general statement that it may not apply in all cases. It is best to have your tires inspected by a tire supplier to determine if your tires need to be replaced.

If you are storing your trailer for an extended period, make sure the tires are fully inflated to the maximum rated pressure and that you store them in a cool, dry place, such as a garage. Use tire covers to protect the trailer tires from the harsh effects of the sun.

2.2 STEPS FOR DETERMINING CORRECT LOAD LIMIT – TRAILER

Determining the load limits of a trailer includes more than understanding the load limits of the tires alone. On all trailers there is a Federal Certification / VIN label that is located on the forward half of the left (road) side of the unit. This certification/VIN label will indicate the trailer's Gross Vehicle Weight Rating (GVWR). This is the most weight the fully loaded trailer can weigh. It will also provide the Gross Axle Weight Rating (GAWR). This is the most a particular axle can weigh. If there are multiple axles, the GAWR of each axle will be provided.

If your trailer has a GVWR of 10,000 pounds or less, there is a vehicle placard located in the same location as the certification label described above. This placard provides tire and loading information. In addition, this placard will show a statement regarding maximum cargo capacity. Cargo can be added to the trailer, up to the maximum weight specified on the placard. The combined weight of the cargo is provided as a single number. In any

case, remember: the total weight of a fully loaded trailer can not exceed the stated GVWR.

For trailers with living quarters installed, the weight of water and propane also need to be considered. The weight of fully filled propane containers is considered part of the weight of the trailer before it is loaded with cargo, and is not considered part of the disposable cargo load. Water however, is a disposable cargo weight and is treated as such. If there is a fresh water storage tank of 100 gallons, this tank when filled would weigh about 800 pounds. If more cargo is being transported, water can be off-loaded to keep the total amount of cargo added to the vehicle within the limits of the GVWR so as not to overload the vehicle. Understanding this flexibility will allow you, the owner, to make choices that fit your travel needs.

When loading your cargo, be sure it is distributed evenly to prevent overloading front to back and side to side. Heavy items should be placed low and as close to the axle positions as reasonable. Too many items on one side may overload a tire. The best way to know the actual weight of the vehicle is to weigh it at a public scale. Talk to your dealer to discuss the weighing methods needed to capture the various weights related to the trailer. This would include the weight empty or unloaded, weights per axle, wheel, hitch or king-pin, and total weight.

Excessive loads and/or underinflation cause tire overloading and, as a result, abnormal tire flexing occurs. This situation can generate an excessive amount of heat within the tire. Excessive heat may lead to tire failure. It is the air pressure that enables a tire to support the load, so proper inflation is critical. The proper air pressure may be found on the Certification / VIN label and/or on the Tire Placard. This value should never exceed the maximum cold inflation pressure stamped on the tire.

Section 2 - Tire Safety Information

2.2.1 Trailers 10,000 Pounds GVWR or Less

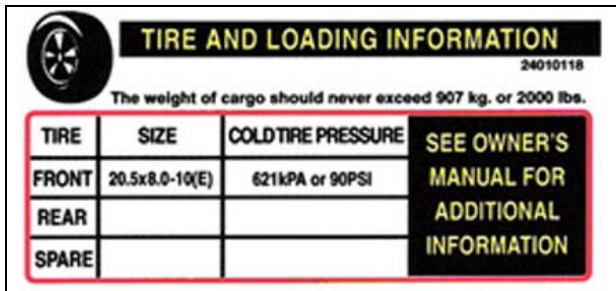

Tire Information Placard - Figure 2-1

1. Locate the statement, “The weight of cargo should never exceed XXX kg or XXX lbs.,” on your vehicle’s placard. See figure 2-1.
2. This figure equals the available amount of cargo and luggage load capacity.
3. Determine the combined weight of luggage and cargo being loaded on the vehicle. That weight may not safely exceed the available cargo and luggage load capacity.

The trailer’s placard refers to the Tire Information Placard attached adjacent to or near the trailer’s VIN (Certification) label at the left front of the trailer.

2.2.2 Trailers Over 10,000 Pounds GVWR

Note: These trailers are not required to have a tire information placard on the trailer and may not have one installed.

1. Determine the empty weight of your trailer by weighing the trailer using a public scale or other means. This step does not have to be repeated.
2. Locate the GVWR (Gross Vehicle Weight Rating) of the trailer on your trailer’s VIN (Certification) label.
3. Subtract the empty weight of your trailer from the GVWR stated on the VIN label. That weight is the maximum available cargo capacity of the trailer and may not be safely exceeded.

2.3 STEPS FOR DETERMINING CORRECT LOAD LIMIT – TOW VEHICLE

1. Locate the statement, “The combined weight of occupants and cargo should never exceed XXX lbs.,” on your vehicle’s placard.

2. Determine the combined weight of the driver and passengers who will be riding in your vehicle.
3. Subtract the combined weight of the driver and passengers from XXX kilograms or XXX pounds.
4. The resulting figure equals the available amount of cargo and luggage capacity. For example, if the “XXX” amount equals 1400 lbs. and there will be five 150 lb. passengers in your vehicle, the amount of available cargo and luggage capacity is 650 lbs. (1400-750 (5 x 150) = 650 lbs.).
5. Determine the combined weight of luggage and cargo being loaded on the vehicle. That weight may not safely exceed the available cargo and luggage capacity calculated in Step # 4.
6. If your vehicle will be towing a trailer, load from your trailer will be transferred to your vehicle. Consult the tow vehicle’s manual to determine how this weight transfer reduces the available cargo and luggage capacity of your vehicle.

2.4 GLOSSARY OF TIRE TERMINOLOGY

Accessory weight

The combined weight (in excess of those standard items which may be replaced) of automatic transmission, power steering, power brakes, power windows, power seats, radio and heater, to the extent that these items are available as factory-installed equipment (whether installed or not).

Bead

The part of the tire that is made of steel wires, wrapped or reinforced by ply cords and that is shaped to fit the rim.

Bead separation

This is the breakdown of the bond between components in the bead.

Bias ply tire

A pneumatic tire in which the ply cords that extend to the beads are laid at alternate angles substantially less than 90 degrees to the centerline of the tread.

Carcass

The tire structure, except tread and sidewall rubber which, when inflated, bears the load.

Section 2 - Tire Safety Information

Chunking

The breaking away of pieces of the tread or sidewall.

Cold inflation pressure

The pressure in the tire before you drive.

Cord

The strands forming the plies in the tire.

Cord separation

The parting of cords from adjacent rubber compounds.

Cracking

Any parting within the tread, sidewall, or inner liner of the tire extending to cord material.

CT

A pneumatic tire with an inverted flange tire and rim system in which the rim is designed with rim flanges pointed radially inward and the tire is designed to fit on the underside of the rim in a manner that encloses the rim flanges inside the air cavity of the tire.

Curb weight

The weight of a motor vehicle with standard equipment including the maximum capacity of fuel, oil, and coolant, and, if so equipped, air conditioning and additional weight optional engine.

Extra load tire

A tire designed to operate at higher loads and at higher inflation pressures than the corresponding standard tire.

Groove

The space between two adjacent tread ribs.

Gross Axle Weight Rating

The maximum weight that any axle can support, as published on the Certification / VIN label on the front left side of the trailer. Actual weight determined by weighing each axle on a public scale, with the trailer attached to the towing vehicle.

Gross Vehicle Weight Rating

The maximum weight of the fully loaded trailer, as published on the Certification / VIN label. Actual weight determined by weighing trailer on a public scale, without being attached to the towing vehicle.

Hitch Weight

The downward force exerted on the hitch ball by the trailer coupler.

Innerliner

The layer(s) forming the inside surface of a tubeless tire that contains the inflating medium within the tire.

Innerliner separation

The parting of the innerliner from cord material in the carcass.

Intended outboard sidewall

The sidewall that contains a white-wall, bears white lettering or bears manufacturer, brand, and/or model name molding that is higher or deeper than the same molding on the other sidewall of the tire or the outward facing sidewall of an asymmetrical tire that has a particular side that must always face outward when mounted on a vehicle.

Light truck (LT) tire

A tire designated by its manufacturer as primarily intended for use on lightweight trucks or multipurpose passenger vehicles. May be used on trailers.

Load rating

The maximum load that a tire is rated to carry for a given inflation pressure.

Maximum load rating

The load rating for a tire at the maximum permissible inflation pressure for that tire.

Maximum permissible inflation pressure

The maximum cold inflation pressure to which a tire may be inflated.

Maximum loaded vehicle weight

The sum of curb weight, accessory weight, vehicle capacity weight, and production options weight.

Measuring rim

The rim on which a tire is fitted for physical dimension requirements.

Non-pneumatic rim

A mechanical device which, when a non-pneumatic tire assembly incorporates a wheel, supports the tire, and attaches, either integrally or separably, to

Section 2 - Tire Safety Information

the wheel center member and upon which the tire is attached.

Non-pneumatic spare tire assembly

A non-pneumatic tire assembly intended for temporary use in place of one of the pneumatic tires and rims that are fitted to a passenger car in compliance with the requirements of this standard.

Non-pneumatic tire

A mechanical device which transmits, either directly or through a wheel or wheel center member, the vertical load and tractive forces from the roadway to the vehicle, generates the tractive forces that provide the directional control of the vehicle and does not rely on the containment of any gas or fluid for providing those functions.

Non-pneumatic tire assembly

A non-pneumatic tire, alone or in combination with a wheel or wheel center member, which can be mounted on a vehicle.

Normal occupant weight

This means 68 kilograms (150 lbs.) times the number of occupants specified in the second column of Table I of 49 CFR 571.110.

Occupant distribution

The distribution of occupants in a vehicle as specified in the third column of Table I of 49 CFR 571.110.

Open splice

Any parting at any junction of tread, sidewall, or innerliner that extends to cord material.

Outer diameter

The overall diameter of an inflated new tire.

Overall width

The linear distance between the exteriors of the sidewalls of an inflated tire, including elevations due to labeling, decorations, or protective bands or ribs.

Pin Weight

The downward force applied to the 5th wheel or gooseneck ball, by the trailer kingpin or gooseneck coupler.

Ply

A layer of rubber-coated parallel cords.

Ply separation

A parting of rubber compound between adjacent plies.

Pneumatic tire

A mechanical device made of rubber, chemicals, fabric and steel or other materials, that, when mounted on an automotive wheel, provides the traction and contains the gas or fluid that sustains the load.

Production options weight

The combined weight of those installed regular production options weighing over 2.3 kilograms (5 lbs.) in excess of those standard items which they replace, not previously considered in curb weight or accessory weight, including heavy duty brakes, ride levelers, roof rack, heavy duty battery, and special trim.

Radial ply tire

A pneumatic tire in which the ply cords that extend to the beads are laid at substantially 90 degrees to the centerline of the tread.

Recommended inflation pressure

This is the inflation pressure provided by the vehicle manufacturer on the Tire Information label and on the Certification / VIN tag.

Reinforced tire

A tire designed to operate at higher loads and at higher inflation pressures than the corresponding standard tire.

Rim

A metal support for a tire or a tire and tube assembly upon which the tire beads are seated.

Rim diameter

This means the nominal diameter of the bead seat.

Rim size designation

This means the rim diameter and width.

Rim type designation

This means the industry of manufacturer's designation for a rim by style or code.

Rim width

This means the nominal distance between rim flanges.

Section 2 - Tire Safety Information

Section width

The linear distance between the exteriors of the sidewalls of an inflated tire, excluding elevations due to labeling, decoration, or protective bands.

Sidewall

That portion of a tire between the tread and bead.

Sidewall separation

The parting of the rubber compound from the cord material in the sidewall.

Special Trailer (ST) tire

The "ST" is an indication the tire is for trailer use only.

Test rim

The rim on which a tire is fitted for testing, and may be any rim listed as appropriate for use with that tire.

Tread

That portion of a tire that comes into contact with the road.

Tread rib

A tread section running circumferentially around a tire.

Tread separation

Pulling away of the tread from the tire carcass.

Treadwear indicators (TWI)

The projections within the principal grooves designed to give a visual indication of the degrees of wear of the tread.

Vehicle capacity weight

The rated cargo and luggage load plus 68 kilograms (150 lbs.) times the vehicle's designated seating capacity.

Vehicle maximum load on the tire

The load on an individual tire that is determined by distributing to each axle its share of the maximum loaded vehicle weight and dividing by two.

Vehicle normal load on the tire

The load on an individual tire that is determined by distributing to each axle its share of the curb weight, accessory weight, and normal occupant weight (distributed in accordance with Table I of CRF 49 571.110) and dividing by 2.

Weather side

The surface area of the rim not covered by the inflated tire.

Wheel center member

In the case of a non-pneumatic tire assembly incorporating a wheel, a mechanical device which attaches, either integrally or separably, to the non-pneumatic rim and provides the connection between the non-pneumatic rim and the vehicle; or, in the case of a non-pneumatic tire assembly not incorporating a wheel, a mechanical device which attaches, either integrally or separably, to the non-pneumatic tire and provides the connection between tire and the vehicle.

Wheel-holding fixture

The fixture used to hold the wheel and tire assembly securely during testing.

2.5 TIRE SAFETY - EVERYTHING RIDES ON IT

The National Traffic Safety Administration (NHTSA) has published a brochure (DOT HS 809 361) that discusses all aspects of Tire Safety, as required by CFR 575.6. This brochure is reproduced in part below. It can be obtained and downloaded from NHTSA, free of charge, from the following web site:

http://www.nhtsa.dot.gov/cars/rules/TireSafety/ridesonit/tires_index.html

Studies of tire safety show that maintaining proper tire pressure, observing tire and vehicle load limits (not carrying more weight in your vehicle than your tires or vehicle can safely handle), avoiding road hazards, and inspecting tires for cuts, slashes, and other irregularities are the most important things you can do to avoid tire failure, such as tread separation or blowout and flat tires. These actions, along with other care and maintenance activities, can also:

- Improve vehicle handling
- Help protect you and others from avoidable breakdowns and accidents
- Improve fuel economy
- Increase the life of your tires.

Section 2 - Tire Safety Information

This booklet presents a comprehensive overview of tire safety, including information on the following topics:

- Basic tire maintenance
- Uniform Tire Quality Grading System
- Fundamental characteristics of tires
- Tire safety tips.

Use this information to make tire safety a regular part of your vehicle maintenance routine. Recognize that the time you spend is minimal compared with the inconvenience and safety consequences of a flat tire or other tire failure.

2.5.1 Safety First—Basic Tire Maintenance

Properly maintained tires improve the steering, stopping, traction, and load-carrying capability of your vehicle. Underinflated tires and overloaded vehicles are a major cause of tire failure. Therefore, as mentioned above, to avoid flat tires and other types of tire failure, you should maintain proper tire pressure, observe tire and vehicle load limits, avoid road hazards, and regularly inspect your tires.

2.5.2 Finding Your Vehicle's Recommended Tire Pressure and Load Limits

Tire information placards and vehicle certification labels contain information on tires and load limits. These labels indicate the vehicle manufacturer's information including:

- Recommended tire size
- Recommended tire inflation pressure
- Vehicle capacity weight (VCW—the maximum occupant and cargo weight a vehicle is designed to carry)
- Front and rear gross axle weight ratings (GAWR—the maximum weight the axle systems are designed to carry).

Both placards and certification labels are permanently attached to the trailer near the left front.

2.5.3 Understanding Tire Pressure and Load Limits

Tire inflation pressure is the level of air in the tire that provides it with load-carrying capacity and affects the overall performance of the vehicle. The

tire inflation pressure is a number that indicates the amount of air pressure—measured in pounds per square inch (psi)—a tire requires to be properly inflated. (You will also find this number on the vehicle information placard expressed in kilopascals (kPa), which is the metric measure used internationally.)

Manufacturers of passenger vehicles and light trucks determine this number based on the vehicle's design load limit, that is, the greatest amount of weight a vehicle can safely carry and the vehicle's tire size. The proper tire pressure for your vehicle is referred to as the "recommended cold inflation pressure." (As you will read below, it is difficult to obtain the recommended tire pressure if your tires are not cold.)

Because tires are designed to be used on more than one type of vehicle, tire manufacturers list the "maximum permissible inflation pressure" on the tire sidewall. This number is the greatest amount of air pressure that should ever be put in the tire under normal driving conditions.

2.5.4 Checking Tire Pressure

It is important to check your vehicle's tire pressure at least once a month for the following reasons:

- Most tires may naturally lose air over time.
- Tires can lose air suddenly if you drive over a pothole or other object or if you strike the curb when parking.
- With radial tires, it is usually not possible to determine underinflation by visual inspection.

For convenience, purchase a tire pressure gauge to keep in your vehicle. Gauges can be purchased at tire dealerships, auto supply stores, and other retail outlets.

The recommended tire inflation pressure that vehicle manufacturers provide reflects the proper psi when a tire is cold. The term cold does not relate to the outside temperature. Rather, a cold tire is one that has not been driven on for at least three hours. When you drive, your tires get warmer, causing the air pressure within them to increase. Therefore, to get an accurate tire pressure reading, you must measure tire pressure when the tires are cold or compensate for the extra pressure in warm tires.

Section 2 - Tire Safety Information

2.5.5 Steps for Maintaining Proper Tire Pressure

- Step 1: Locate the recommended tire pressure on the vehicle's tire information placard, certification label, or in the owner's manual.
- Step 2: Record the tire pressure of all tires.
- Step 3: If the tire pressure is too high in any of the tires, slowly release air by gently pressing on the tire valve stem with the edge of your tire gauge until you get to the correct pressure.
- Step 4: If the tire pressure is too low, note the difference between the measured tire pressure and the correct tire pressure. These "missing" pounds of pressure are what you will need to add.
- Step 5: At a service station, add the missing pounds of air pressure to each tire that is underinflated.
- Step 6: Check all the tires to make sure they have the same air pressure (except in cases in which the front and rear tires are supposed to have different amounts of pressure).

If you have been driving your vehicle and think that a tire is underinflated, fill it to the recommended cold inflation pressure indicated on your vehicle's tire information placard or certification label. While your tire may still be slightly underinflated due to the extra pounds of pressure in the warm tire, it is safer to drive with air pressure that is slightly lower than the vehicle manufacturer's recommended cold inflation pressure than to drive with a significantly underinflated tire. Since this is a temporary fix, don't forget to recheck and adjust the tire's pressure when you can obtain a cold reading.

2.5.6 Tire Size

To maintain tire safety, purchase new tires that are the same size as the vehicle's original tires or another size recommended by the manufacturer. Look at the tire information placard, the owner's manual, or the sidewall of the tire you are replacing to find this information. If you have any doubt about the correct size to choose, consult with the tire dealer.

2.5.7 Tire Tread

The tire tread provides the gripping action and traction that prevent your vehicle from slipping or sliding, especially when the road is wet or icy. In

general, tires are not safe and should be replaced when the tread is worn down to 1/16 of an inch. Tires have built-in treadwear indicators that let you know when it is time to replace your tires. These indicators are raised sections spaced intermittently in the bottom of the tread grooves. When they appear "even" with the outside of the tread, it is time to replace your tires. Another method for checking tread depth is to place a penny in the tread with Lincoln's head upside down and facing you. If you can see the top of Lincoln's head, you are ready for new tires.

2.5.8 Tire Balance and Wheel Alignment

To avoid vibration or shaking of the vehicle when a tire rotates, the tire must be properly balanced. This balance is achieved by positioning weights on the wheel to counterbalance heavy spots on the wheel-and-tire assembly. A wheel alignment adjusts the angles of the wheels so that they are positioned correctly relative to the vehicle's frame. This adjustment maximizes the life of your tires. These adjustments require special equipment and should be performed by a qualified technician.

2.5.9 Tire Repair

The proper repair of a punctured tire requires a plug for the hole and a patch for the area inside the tire that surrounds the puncture hole. Punctures through the tread can be repaired if they are not too large, but punctures to the sidewall should not be repaired. Tires must be removed from the rim to be properly inspected before being plugged and patched.

2.5.10 Tire Fundamentals

Federal law requires tire manufacturers to place standardized information on the sidewall of all tires. This information identifies and describes the fundamental characteristics of the tire and also provides a tire identification number for safety standard certification and in case of a recall.

Section 2 - Tire Safety Information

2.5.10.a Information on Passenger Vehicle Tires

Please refer to the diagram below.

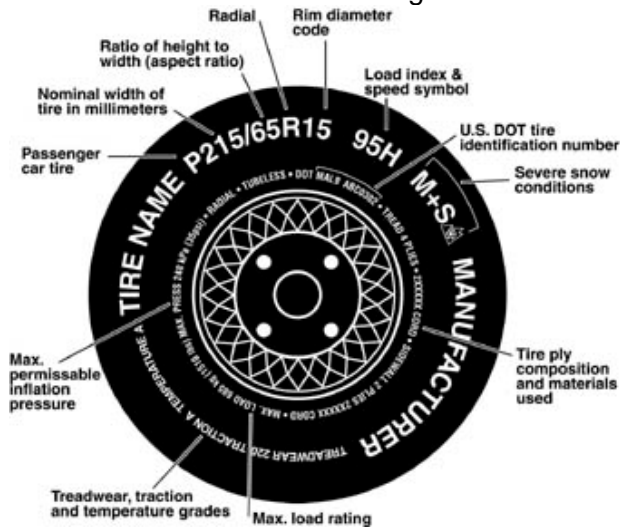

P

The "P" indicates the tire is for passenger vehicles.

Next number

This three-digit number gives the width in millimeters of the tire from sidewall edge to sidewall edge. In general, the larger the number, the wider the tire.

Next number

This two-digit number, known as the aspect ratio, gives the tire's ratio of height to width. Numbers of 70 or lower indicate a short sidewall for improved steering response and better overall handling on dry pavement.

R

The "R" stands for radial. Radial ply construction of tires has been the industry standard for the past 20 years.

Next number

This two-digit number is the wheel or rim diameter in inches. If you change your wheel size, you will have to purchase new tires to match the new wheel diameter.

Next number

This two- or three-digit number is the tire's load index. It is a measurement of how much weight each tire can support. You may find this information in your owner's manual. If not, contact a local tire dealer. Note: You may not find this information on all tires because it is not required by law.

M+S

The "M+S" or "M/S" indicates that the tire has some mud and snow capability. Most radial tires have these markings; hence, they have some mud and snow capability.

Speed Rating

The speed rating denotes the speed at which a tire is designed to be driven for extended periods of time. Note: You may not find this information on all tires because it is not required by law.

U.S. DOT Tire Identification Number

This begins with the letters "DOT" and indicates that the tire meets all federal standards. The next two numbers or letters are the plant code where it was manufactured, and the last four numbers represent the week and year the tire was built. For example, the numbers 3197 means the 31st week of 1997. The other numbers are marketing codes used at the manufacturer's discretion. This information is used to contact consumers if a tire defect requires a recall.

Tire Ply Composition and Materials Used

The number of plies indicates the number of layers of rubber-coated fabric in the tire. In general, the greater the number of plies, the more weight a tire can support. Tire manufacturers also must indicate the materials in the tire, which include steel, nylon, polyester, and others.

Maximum Load Rating

This number indicates the maximum load in kilograms and pounds that can be carried by the tire.

Maximum Permissible Inflation Pressure

This number is the greatest amount of air pressure that should ever be put in the tire under normal driving conditions.

2.5.10.b UTQGS Information

Treadwear Number

This number indicates the tire's wear rate. The higher the treadwear number is, the longer it should take for the tread to wear down. For example, a tire graded 400 should last twice as long as a tire graded 200.

Traction Letter

This letter indicates a tire's ability to stop on wet pavement. A higher graded tire should allow you to

Section 2 - Tire Safety Information

stop your car on wet roads in a shorter distance than a tire with a lower grade. Traction is graded from highest to lowest as "AA", "A", "B", and "C".

Temperature Letter

This letter indicates a tire's resistance to heat. The temperature grade is for a tire that is inflated properly and not overloaded. Excessive speed, underinflation or excessive loading, either separately or in combination, can cause heat build-up and possible tire failure. From highest to lowest, a tire's resistance to heat is graded as "A", "B", or "C".

2.5.10.c Information on Light Truck (LT) Tires

Please refer to the following diagram.

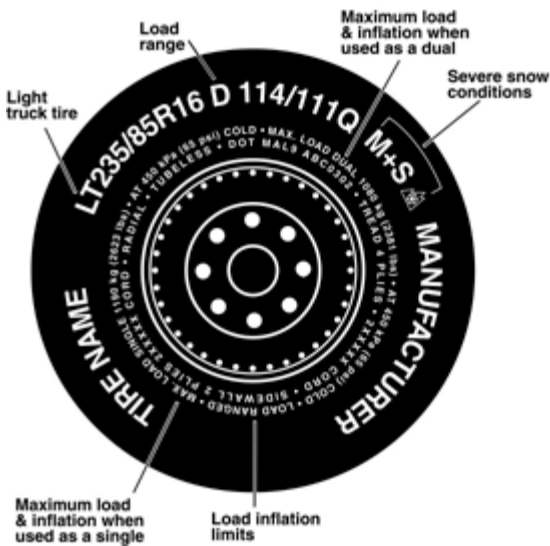

Tires for light trucks have other markings besides those found on the sidewalls of passenger tires.

LT

The "LT" indicates the tire is for light trucks or trailers.

Max. Load Dual kg (lbs) at kPa (psi) Cold

This information indicates the maximum load and tire pressure when the tire is used as a dual, that is, when four tires are put on each rear axle (a total of six or more tires on the vehicle).

Max. Load Single kg (lbs) at kPa (psi) Cold

This information indicates the maximum load and tire pressure when the tire is used as a single.

Load Range

This information identifies the tire's load-carrying capabilities and its inflation limits.

2.5.10.d Information on Special Trailer (ST) Tires

Please refer to the following diagram.

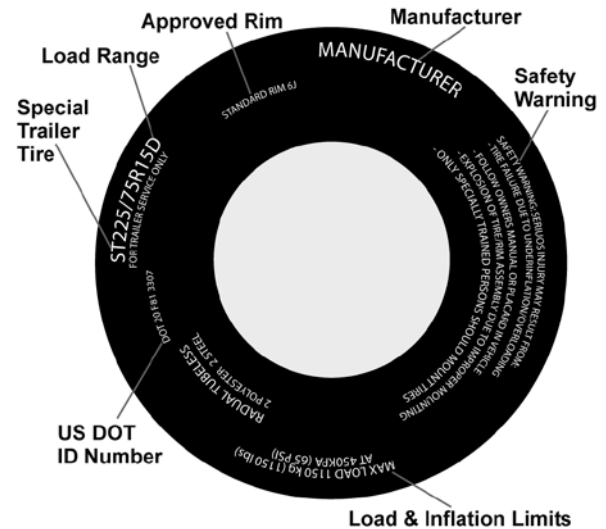

Tires designated for trailers only have other markings besides those found on the sidewalls of passenger tires.

ST

An "ST" is an indication the tire is for trailer use only. "ST" tires are design for carrying heavy loads at lower speeds.

The Tire and Rim Association Standard indicates that for operation at speeds up to 65 mph, no change in maximum cold tire inflation pressure or load is required. For speeds between 66-75 mph, increase the maximum cold tire inflation pressure 10 psi.

Max. Load Dual kg (lbs) at kPa (psi) Cold

This information indicates the maximum load and tire pressure when the tire is used as a dual, that is, when four tires are put on each rear axle (a total of six or more tires on the vehicle).

Max. Load Single kg (lbs) at kPa (psi) Cold

This information indicates the maximum load and tire pressure when the tire is used as a single.

Load Range

This information identifies the tire's load-carrying capabilities and its inflation limits.

Section 2 - Tire Safety Information

2.5.11 Tire Safety Tips

Preventing Tire Damage

- Slow down if you have to go over a pothole or other object in the road.
- Do not run over curbs or other foreign objects in the roadway, and try not to strike the curb when parking.

Tire Safety Checklist

- Check tire pressure regularly (at least once a month), including the spare.
- Inspect tires for uneven wear patterns on the tread, cracks, foreign objects, or other signs of wear or trauma.
- Remove bits of glass and foreign objects wedged in the tread.
- Make sure your tire valves have valve caps.
- Check tire pressure before going on a long trip.
- Do not overload your vehicle. Check the tire information placard or owner's manual for the maximum recommended load for the vehicle.

3 COUPLING TO THE TOW VEHICLE

This manual provides instructions for the operation and care of Featherlite Tram Trailers. The instructions in the manual must be followed to ensure safety and satisfactory life of the trailer. Safety precautions to protect against injury or property damage must be followed at all times.

This section of the manual is organized into the following subsections:

- Using an adequate tow vehicle and hitch
- Coupling the trailer to the tow vehicle
- Loading passengers
- Checking the trailer for safety before each tow
- Breaking in a new trailer
- Synchronizing the brakes
- Uncoupling the trailer

3.1 USE AN ADEQUATE TOW VEHICLE AND HITCH

If the tow vehicle or hitch is not properly selected and matched to the Gross Vehicle Weight Rating (GVWR) of your trailer, you can cause an accident that could lead to death or serious injury. Tow vehicle and hitch manufacturers are the appropriate source of competent advice.

If you already have a tow vehicle, know your vehicle tow rating and make certain the trailer's rated capacity is less than or equal to the tow vehicle's rated towing capacity.

⚠ DANGER

Use of an under-rated hitch, ball or tow vehicle can result in loss of control leading to death or serious injury.

Make certain your hitch and tow vehicle are rated for your trailer.

3.1.1 Trailer Information

The "Trailer Certification (VIN) Tag" location figure shows the location of the Certification / Vehicle Identification Number (VIN) tag on your trailer. See figure 3-1.

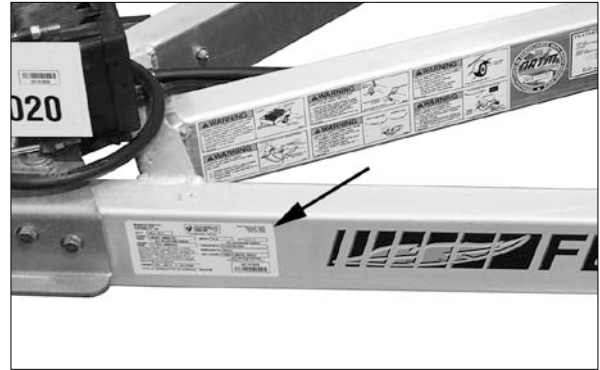

*Gooseneck Certification (VIN) Tag Location -
Figure 3-1*

The trailer Certification (VIN) tag contains the following critical safety information for the use of your trailer:

MANUFACTURER: Name of trailer manufacturer

DATE OF MANUFACTURE: Month and year the trailer was manufactured.

GAWR: The Gross Axle Weight Rating is the maximum gross weight that an axle can support. It is the lowest of axle, wheel, or tire rating. Sometimes the tire or wheel rating is lower than the axle manufacturers rating, and will then determine GAWR.

GVWR: The Gross Vehicle Weight Rating is the maximum allowable gross weight of the trailer and passengers. GVWR is sometimes referred to as GTW (Gross Trailer Weight), or MGTW (Maximum Gross Trailer Weight). GVWR, GTW and MGTW are all the same rating.

The sum total of the GAWR for all trailer axles may be less than the GVWR for the trailer, because some of the trailer load is carried by the tow vehicle, rather than by the trailer axle(s). **The total weight of the passengers and trailer must not exceed the GVWR, and the load on an axle must not exceed its GAWR.**

PSIC: The "pounds per square inch-cold" is the tire pressure (Kilopascals / Pounds per Square Inch) measured when Cold.

Section 3 - Coupling To The Tow Vehicle

VIN: The Vehicle Identification Number.

VEHICLE TYPE: Trailer plus the model number of the trailer.

Certification Statement: “This trailer meets all the Federal Motor Vehicle Safety Standards in effect on the date of manufacture shown above.”

There are two additional weights that are not provided on the Certification (VIN) tag that are important, and that should be put somewhere on the trailer. These are the “empty weight” and “maximum cargo weight”.

The “empty weight” is sometimes put on the Manufacturer’s Certificate of Origin (Title) but may not be accurate for your particular trailer, due to accessories, optional equipment, etc. The best way to determine empty weight is to weigh the entire trailer on a “Certified” scale at a truck stop. This requires detaching the trailer and leaving the entire trailer on the scale. Furthermore, it is desirable to weigh the tongue weight. This can be done by re-attaching the trailer to the tow vehicle, after getting the empty weight, and then just weighing the trailer axles(s). Subtracting the axle weight from the empty weight gives you the tongue weight.

Knowing the empty weight now allows you to calculate the “maximum cargo weight”. Simply subtract the empty weight from the GVWR shown on the Certification / VIN tag.

While you’re at the scale it is also a good idea to weigh the towing vehicle, with driver, in the typical towing scenario. This will provide you with the total “combination vehicle weight”, which can then be compared to the allowable Gross Combined Weight Rating (GCWR) provided by the tow vehicle manufacturer, as discussed below.

3.1.2 Tow Vehicle

When equipping a new vehicle or an older vehicle to tow your trailer, ask the vehicle dealer for advice on how to outfit the towing vehicle. Discuss the following information and equipment with the vehicle dealer.

Overall Carrying and Towing Capacity of Vehicle: Vehicle manufacturers will provide you with the maximum towing capacities of their various models, as well as the GCWR. No amount

of reinforcement will give a 100 horsepower, 2,500 pound truck the towing capacity that a 300 horsepower, 5,000 pound truck has.

Towing Hitch: The towing hitch attached to your tow vehicle must have a capacity equal to or greater than the load rating of the trailer you intend to tow. The hitch capacity must also be matched to the tow vehicle capacity.

Suspension System: A tow vehicle equipped with a factory installed “Towing Package” likely comes equipped with heavy duty springs, heavy duty tires and other suspension components which are able to serve the size and weight of the trailer that the vehicle is rated to tow. However, the addition of additional equipment may further improve the tow vehicle performance. These may include adjustable air shocks, helper springs, etc.

Brake Controller: The brake controller is part of the tow vehicle and is essential in the operation of the electric brakes on the trailer. If your trailer has electric brakes it requires a brake controller be installed at the driver’s position. The brake controller is not the same as the safety breakaway brake system that is installed on the trailer.

Side View Mirrors: The size of the trailer that is being towed and your state law regulations determine the size of the mirrors. However, some states prohibit extended mirrors on a tow vehicle, except while a trailer is actually being towed. In this situation, detachable extended mirrors are necessary. Check with your dealer or the appropriate state agency for mirror requirements.

Heavy Duty Flasher: A Heavy Duty Flasher is an electrical component that may be required when your trailer turn signal lights are attached to the tow vehicle flasher circuit.

Electrical Connector: An Electrical Connector connects the light and brake systems on the trailer to the light and brake controls on the towing vehicle.

Heavy Duty Engine Oil Cooling System: The tow vehicle engine works harder when a trailer is being towed. Depending on the size of the trailer, you may need to install a separate engine oil cooler. Inadequate cooling may result in sudden engine

Section 3 - Coupling To The Tow Vehicle

failure. Ask the tow vehicle dealer if it is necessary to install a heavy duty cooling system.

Automatic Transmission Oil Cooler: The automatic transmission of a towing vehicle handles more power when a trailer is being towed. Inadequate cooling will shorten transmission life, and may result in sudden transmission failure. Ask the tow vehicle dealer if it is necessary to install a separate oil cooler for the automatic transmission.

Fire Extinguisher: It is sensible to have a fire extinguisher in the tow vehicle.

Emergency Flares and Emergency Triangle Reflectors: It is wise to carry these warning devices even if you are not towing a trailer. It is particularly important to have these when towing a trailer because the hazard flashers of your towing vehicle will not operate for as long a period of time when the battery is running both the trailer lights and tow vehicle lights.

3.2 COUPLING AND UNCOUPLING THE TRAILER

A secure coupling (or fastening) of the trailer to the tow vehicle is essential. A loss of coupling may result in death or serious injury. Therefore, you must understand and follow all of the instructions for coupling.

The following parts are involved in making a secure coupling between the trailer and tow vehicle:

Coupling: That part of the trailer connecting mechanism by which the connection is actually made to the trailer hitch. This does not include any structural member, extension of the trailer frame, or brake controller. (per SAE J684)

Hitch: That part of the connecting mechanism including the ball support platform and ball and those components that extend and are attached to the towing vehicle, including bumpers intended to serve as hitches. (per SAE J684)

Safety chains: Chains are permanently attached to the trailer such that if the coupler connection comes loose, the safety chains can keep the trailer attached to the tow vehicle. With properly rigged safety chains, it is possible to keep the tongue of the trailer

from digging into the road pavement, even if the coupler-to-hitch connection comes apart.

Trailer lighting (and braking) connector: A device that connects electrical power from the tow vehicle to the trailer. Electricity is used to turn on brake lights, running lights, and turn signals as required. The electrical connector will also supply power to the trailer brakes from the tow vehicle.

Breakaway switch: If the trailer becomes decoupled from the towing vehicle, the breakaway switch lanyard, attached independently to the tow vehicle hitch, will pull a pin in the emergency electrical breakaway switch on the trailer. The breakaway switch is activated by a separate battery supply in the trailer such as to energize the trailer brakes independently of the towing vehicle. It is important to check the state of charge of the emergency breakaway battery before each trip. Simply pull the pin out of the switch by hand and then try to pull the trailer. If you feel a significant drag force the brakes are activated. Be sure to reinsert the pin in the breakaway switch. Also be sure to allow enough slack in the breakaway brake lanyard such that the switch will only activate (pin pulls out) if the coupler connection comes loose.

Jack: A device on the trailer that is used to raise and lower the trailer tongue.

WARNING

An improperly coupled trailer can result in death or serious injury.

Do not move the trailer until:

- **The coupler is secured and locked;**
- **The safety chains are secured to the tow vehicle; and**
- **The trailer jacks are fully retracted.**
- **Do not tow the trailer until:**
- **The trailer brakes are checked;**
- **The breakaway switch is connected to the tow vehicle;**
- **The trailer lights are connected and checked.**

If the coupler on your trailer does not resemble the couplers shown in the figures, see the separate coupler instructions. If you do not have separate

Section 3 - Coupling To The Tow Vehicle

coupler instructions, call Featherlite, Inc. at 800-800-1230 for assistance.

3.2.1 Ball Hitch Coupler

Be sure the ball hitch coupler is suitable for the size and weight of the trailer. The load rating of the coupler and the necessary ball size are listed on the trailer tongue. You must provide a hitch and ball for your tow vehicle, where the load rating of the hitch and ball is equal to or greater than that of your trailer. Also, the ball size must be the same as the coupler size. If the hitch ball is too small, too large, is underrated, is loose or is worn, the trailer can come loose from the tow vehicle, and may cause death or serious injury.

THE TOW VEHICLE, HITCH AND BALL MUST HAVE A RATED TOWING CAPACITY EQUAL TO OR GREATER THAN THE TRAILER Gross Vehicle Weight Rating (GVWR).

IT IS ESSENTIAL THAT THE HITCH BALL BE OF THE SAME SIZE AS THE COUPLER.

IF THE HITCH BALL IS TOO SMALL, IS UNDERRATED, IS LOOSE OR IS WORN, THE TRAILER CAN COME LOOSE FROM THE TOW VEHICLE, RESULTING IN DEATH OR SERIOUS INJURY.

The ball size and load rating (capacity) are marked on the ball; hitch capacity is marked on the hitch.

3.2.1.a Before Coupling Trailer to Tow Vehicle

- Be sure the size and rating of hitch ball match the size and rating of the coupler. Hitch balls and couplers are marked with their size and rating.

WARNING

Coupler-to-hitch mismatch can result in uncoupling, leading to death or serious injury.

Make sure the hitch and ball are rated for the trailer coupling.

Make sure the hitch [ball size] matches the coupler.

- Wipe the hitch ball clean and inspect it visually and by feel for flat spots, cracks and pits.

WARNING

A worn, cracked or corroded hitch ball can fail while towing, and may result in death or serious injury.

Check the hitch ball for wear, corrosion and cracks before coupling the trailer.

Replace worn, corroded or cracked hitch ball before coupling the trailer.

- Rock the ball to make sure it is tight to the hitch, and visually check that the hitch ball nut is solid against the lock washer and hitch frame.
- Wipe the inside and outside of the coupler clean and inspect it visually for cracks and deformations; feel the inside of the coupler for worn spots and pits.
- Be sure the coupler is tight to the tongue of the trailer. All coupler fasteners must be visibly solid against the trailer frame.

WARNING

A loose hitch ball nut can result in uncoupling, leading to death or serious injury.

Make sure the hitch ball is tight to the hitch before coupling the trailer.

3.2.1.b Prepare the Coupler and Hitch

- Lubricate the hitch ball and the inside of the coupler with a thin layer of automotive bearing grease. Using the jack, raise the coupler above the ball height.
- Open the coupler locking mechanism. Ball couplers have a locking mechanism with an internal moving piece (ball clamp) and an outside handle, wheel, or latch. See figure 3-3.
 - In the open or unlatched position, the coupler is able to drop fully onto the hitch ball.
 - See the coupler instructions for details of placing the coupler in the open or unlatched position.
- Slowly back up the tow vehicle so that the hitch ball is near or aligned under the coupler, if the trailer jack has raised the coupler.

Section 3 - Coupling To The Tow Vehicle

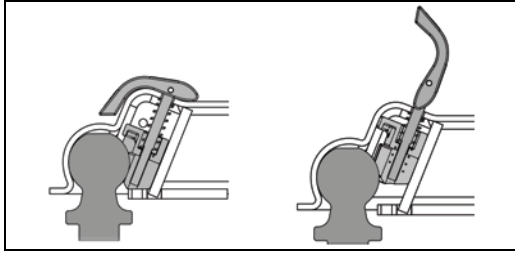

Latched and Unlatched Position - Figure 3-2

3.2.1.c Couple Trailer to Tow Vehicle

- Using the jack, lower the trailer tongue until the coupler fully engages the hitch ball. If the coupler does not line up with the hitch ball, adjust the position of the tow vehicle.
- Lower the trailer to the ball (do not lift handle), while the coupler is going over the ball the handle will lift up automatically and lock over ball as it is lowered.

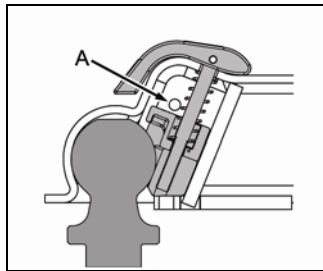

Latched Position - Figure 3-3

- There is no need to insert a pin into the hole (A). With the handle down it is securely locked. This hole is used for security only.
- Be sure the coupler is all the way on the hitch ball and the locking mechanism is latched. A properly engaged locking mechanism will allow the coupler to raise the rear of the tow vehicle. Using the trailer jack, test to see that you can raise the rear of the tow vehicle by 1 inch, after the coupler is locked to the hitch.

NOTICE

The tongue jack can be damaged by overloading. Do not use the tongue jack to raise the tow vehicle more than 1 inch.

If the coupler cannot be secured to the hitch ball, do not tow the trailer. Call Featherlite, Inc. at 800-800-1230 or your dealer for assistance.

- Lower the trailer so that its entire tongue weight is held by the hitch, and continue retracting the jack to its fully retracted position.

3.2.1.d Rig Safety Chains

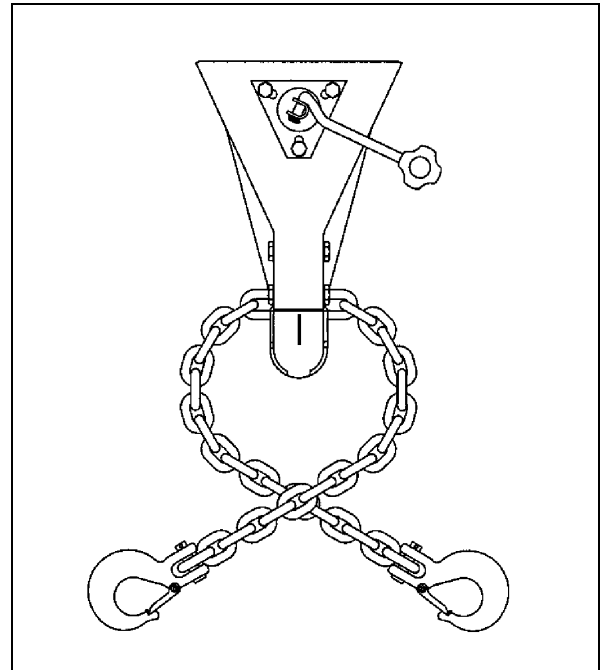

Safety Chain Arrangement - Figure 3-4

- Visually inspect the safety chains and hooks for wear or damage. Replace worn or damaged safety chains and hooks before towing.
- Rig the safety chains so that they:
 - Cris-cross underneath the coupler so if the trailer uncouples, the safety chains can hold the tongue up above the road. See figure 3-4.
 - Loop around a frame member of the tow vehicle or to holes provided in the hitch system (but, do **not** attach them to an interchangeable part of the hitch assembly)
 - Attach hooks up from underneath the hole (do not just drop into hole); and
 - Provide enough slack to permit tight turns, but not be close to the road surface to drag.

Section 3 - Coupling To The Tow Vehicle

⚠ WARNING

Incorrect rigging of the safety chains can result in loss of control of the trailer and tow vehicle, leading to death or serious injury, if the trailer uncouples from the tow vehicle.

Chains must:

- Fasten to frame of tow vehicle, not to hitch or ball.
- Cross underneath hitch and coupler with minimum slack to permit turning and to hold tongue up, if the trailer comes loose.

3.2.1.e Attach and Test Breakaway Brake System

If the coupler or hitch fails, a properly connected and working breakaway brake system will apply electric brakes on the trailer. The safety chains will keep the tow vehicle attached and as the brakes are applied at the trailer's axles, the trailer/tow vehicle combination will come to a controlled stop.

The breakaway brake system includes a controller, battery, and a switch with a pullpin, and lanyard. Read and follow the instructions here as well as the instructions that have been prepared by the breakaway brake manufacturer.

The breakaway brake system may be fitted with a "charging" capability that draws power from the tow vehicle. If the electrical system on your tow vehicle does not provide power to the breakaway brake battery, you must periodically charge the battery to keep the breakaway brake system in working order.

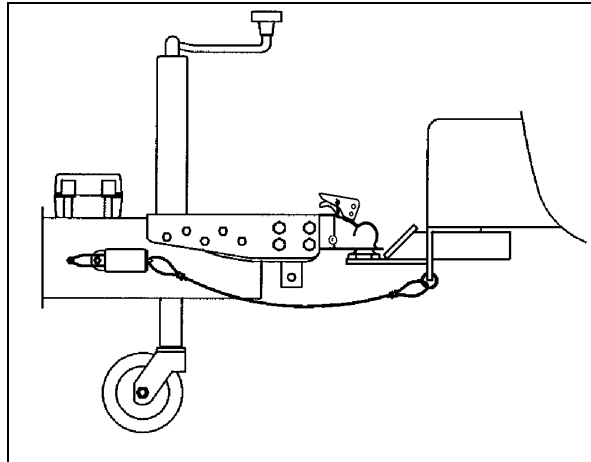

Breakaway Brake Connection - figure 3-5

- Visually inspect the breakaway system for broken or missing parts. Repair or replace worn, damaged or missing parts before towing trailer.
- Connect the pullpin lanyard to the tow vehicle so that the pullpin will be pulled out before all of the slack in the safety chains is taken up (see Breakaway Brake Connection figure 3-5). Do **not** connect the pullpin lanyard to a safety chain or to the hitch ball or hitch ball assembly. This would keep the breakaway brake system from operating when it is needed.
- To test the breakaway brake battery, remove the pullpin from the switch and attempt to pull the trailer forward. You should feel the trailer resisting being towed, but the wheels will not necessarily be locked. If the brakes do not function, do not tow the trailer until brakes, or battery, are repaired.
- Immediately replace the pullpin. The breakaway brake system battery discharges rapidly when the pullpin is removed.

Section 3 - Coupling To The Tow Vehicle

WARNING

An ineffective breakaway brake system can result in a runaway trailer, leading to death or serious injury if the coupler or ball hitch fails.

Test the function of the breakaway brake system before towing the trailer. Do not tow the trailer if the breakaway brake system is not working; have it serviced or repaired.

Connect the breakaway lanyard to the tow vehicle -

NOT to the safety chain; and

NOT to the hitch, ball or support.

Do **not** tow the trailer with the breakaway brake system ON because the brakes will overheat which can result in permanent brake failure.

WARNING

Failure to replace the pullpin can result in ineffective brakes, leading to loss of control, serious injury or death.

If you do not use your trailer for three or more months, or during winter months:

- Store the battery indoors; and
- Charge the battery every three months.

Replace the breakaway brake battery according to the intervals specified by the battery manufacturer.

3.2.1.f Connect Electrical Cables

Connect the trailer lights to the tow vehicle's electrical system using the electrical connectors.

- Check all lights for proper operation.
 - Running Lights (Turn on tow vehicle headlights).
 - Brake Lights (Step on tow vehicle brake pedal).
 - Turn Signals (Operate tow vehicle directional signal lever).
- Check electric brakes for proper operation using brake controller mounted in the cab.

Your tow vehicle will have an electric brake controller that sends power to the trailer brakes. Before towing the trailer, you must operate the brake controller while trying to pull the trailer in order to confirm that the electric brakes operate. While towing the trailer at less than 5 m.p.h., manually operate the electric brake controller in the tow vehicle cab. You should feel the operation of the trailer brakes.

WARNING

Failure to connect the tow vehicle lighting and braking to the trailer will result in inoperable lights and brakes, and can lead to collision.

Check that all the trailer lights and brakes work before each tow.

3.2.2 Connect Rear/Second Trailer

WARNING

Prevent serious injury or death.

Two trailers is the maximum that can be pulled behind a tow vehicle for passenger transport.

One trailer is the maximum that can be pulled for travel on public roads.

The tram trailer is equipped with a rear receiver hitch to pull a second trailer. Repeat procedure in Section 3.2.1 to couple trailer.

Section 3 - Coupling To The Tow Vehicle

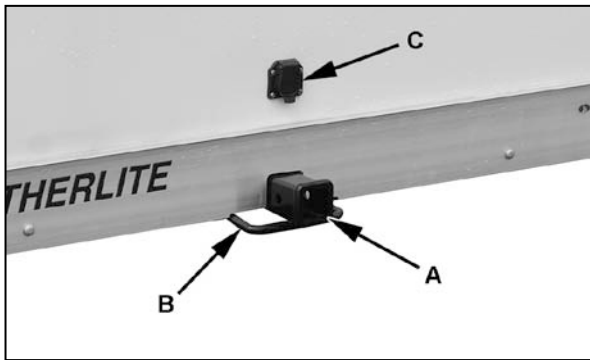

Trailer Rear Receiver - figure 3-7

- A - Rear Receiver
- B - Safety Chain Connection Point
- C - 7-Pin Connector

3.2.3 Uncoupling Trailers

Follow these steps to uncouple your trailer from the tow vehicle:

⚠ WARNING
<p>Prevent serious injury or death.</p> <p>Uncouple rear trailer first before disconnecting front trailer from tow vehicle.</p>

⚠ Disconnect rear trailer first.

1. Block trailer tires to prevent the trailer from rolling, before jacking the trailer up.
2. Disconnect the electrical connector.
3. Disconnect the breakaway brake switch lanyard.
4. Disconnect the safety chains.
5. Unlock the coupler and open it.
6. Before extending jack, make certain the ground surface below the jack pad will support the tongue load.
7. Rotate the jack handle clockwise to extend the jack and transfer the weight of the trailer tongue to the jack.
8. Repeat steps 1-7 to disconnect trailer from tow vehicle.

4 LOADING PASSENGERS

To determine that you have loaded the trailer within its rating, you must consider the *distribution* of weight, as well as the total weight of the trailer and its contents. The trailer axles carry most of the total weight of the trailer and its contents (Gross Vehicle Weight, or “GVW”).

The remainder of the total weight is carried by the tow vehicle hitch. It is essential for safe towing that the trailer tongue and tow vehicle hitch carry the proper amount of the loaded trailer weight, otherwise the trailer can develop an undesirable sway at towing speeds, or the rear of the towing vehicle can be overloaded. Read the “Tongue Weight” section that follows.

The load distribution must be such that no component part of the trailer is loaded beyond its rating. This means that you must consider the rating of the tires, wheels and axles. For tandem and triple axle trailers, you must make sure that the front-to-rear load distribution does not result in overloading any axle.

 WARNING
<p>An overloaded trailer can result in failure or in loss of control of the trailer, leading to death or serious injury.</p> <p>Never load a trailer so that the weight on any tire exceeds its rating.</p> <p>Never exceed the trailer Gross Vehicle Weight Rating (GVWR).</p> <p>Never exceed an axle Gross Axle Weight Rating (GAWR).</p>

4.1 TONGUE WEIGHT

It is critical to have a portion of the trailer load carried by the tow vehicle. That is, the trailer tongue must exert a downward force on the hitch. This is necessary for two reasons. First, the proper amount of tongue weight is necessary for the tow vehicle to be able to maintain control of the tow vehicle/trailer system. If, for example, the tongue exerts an upward pull on the hitch, instead of pushing down on it (because the trailer is

overloaded behind its axles), the rear wheel of the tow vehicle can lose traction or grip and cause loss of control. Also, even if there is some weight on the tongue, but not enough weight on the tongue, the trailer can become unstable.

If, on the other hand, there is too much tongue weight, the tow vehicle is prone to jack-knife. Furthermore, the front wheels of the tow vehicle can be too lightly loaded and cause loss of steering control and traction, if the front wheels are driving.

In addition to tow vehicle control, tongue weight is necessary to insure that the trailer axles do not exceed their Gross Axle Weight Rating (GAWR).

For example, a trailer with a loaded weight of 4,000 pounds, should have 10-15% of 4,000 pounds (400-600 lbs.) on the hitch. After loading, be sure to check that none of the axles are overloaded.

 WARNING
<p>An improperly distributed load can result in loss of control of the trailer, and can lead to death or serious injury.</p> <p>Proper tongue weight is essential for stable trailer handling.</p>

4.2 LOADING PASSENGERS

 WARNING
<p>Do not connect more than two trams behind a tow vehicle.</p> <p>Do not overload tram.</p> <p>Do not exceed 15 mph while transporting passengers.</p>

Couple the trailer to the tow vehicle before loading.

Your trailer is designed to transport up to 28 people (6600 lbs.) on non-public roads at less than 15 mph. One trailer may be coupled to the first trailer for a total of two tram trailers behind a tow vehicle.

Section 4 - Loading The Trailer

⚠ Do not connect more than two trailers behind a properly rated and equipped tow vehicle.

Before loading your open trailer, inspect the floor of the trailer.

If equipped with a wheel chair ramp, inspect “D”-ring hold-downs, and track system used to secure wheel chairs. Inspect the “D”-rings and track system for looseness or signs of bending before loading the trailer.

Passengers must be seated with children on the inside.

5 CHECKING THE TRAILER BEFORE AND DURING EACH TOW

5.1 PRE-TOW CHECKLIST

Before towing, double-check all of these items:

- Tires, wheels and lug nut tightness (torque) (see the “Safety Information” section of this manual).
- Tire Pressure. Inflate tires on trailer and tow vehicle to the value indicated on the Certification / VIN label.
- Couplers secured and locked (see the “Coupling to the Tow Vehicle” section of this manual).
- Safety chains properly rigged to tow vehicle, not to hitch or ball (see the “Coupling to the Tow Vehicle” section of this manual).
- Test Tail, Stop, and Turn Lights.
- Test trailer brakes.

- Safety breakaway switch lanyard fastened to tow vehicle, not to safety chains (see the “Coupling to the Tow Vehicle” chapter of this manual).
- Passenger seated with children on the inside.
- Weight balanced.
- Fire extinguisher.
- Flares and reflectors.

5.2 MAKE REGULAR STOPS

After each 50 miles, or one hour of towing, stop and check the following items:

- Coupler secured.
- Safety chains are fastened and not dragging.
- Check tires for signs of abnormal wear and loss of air pressure.

6 BREAKING-IN A NEW TRAILER

6.1 RETIGHTEN LUG NUTS AT FIRST 10, 25 & 50 MILES

Wheel lugs can shift and settle quickly after being first assembled, and must be checked after the **first** 10, 25 and 50 miles of driving. Failure to perform this check may result in a wheel coming loose from the trailer, causing a crash leading to death or serious injury. Refer to the “Inspection, Service & Maintenance” section for the proper tightening sequence and torque value for the wheel lugs nuts (bolts).

WARNING

Lug nuts are prone to loosen after being first assembled. Death or serious injury can result.

Check lug nuts for tightness on a new trailer, and after re-mounting a wheel at 10, 25 and 50 miles.

6.2 ADJUST BRAKE SHOES AT FIRST 200 MILES

WARNING

Brakes that are out of adjustment can result in death or serious injury.

Brakes must be adjusted at the intervals specified.

Brake shoes and drums experience a rapid initial wear. The brakes **must** be adjusted after the first 200 miles of use, and each 3,000 miles thereafter. Most axles are fitted with brake shoes that must be manually adjusted. Read your axle and brake manual to see if your brakes must be adjusted manually or if they adjust automatically. If you do not have the axle and brake manual, call Featherlite, Inc. at 800-800-1230 for assistance.

To adjust the trailer brakes, see section 8.2.3.c, “Manually Adjusting Brake Shoes,” for instructions.

6.3 SYNCHRONIZING THE BRAKE SYSTEMS

Trailer brakes are designed to work in synchronization with the brakes on the tow vehicle.

When the tow vehicle and trailer braking systems are synchronized, both braking systems contribute to slowing, and the tongue of the trailer will neither dive nor rise sharply.

WARNING

If trailer and tow vehicle brakes do not work properly together, death or serious injury can occur.

Road test the brakes in a safe area at no more than 30 m.p.h. before each tow

To insure safe brake performance and synchronization, read and follow the axle/brake and the brake controller manufacturers’ instructions.

6.4 TIRE PRESSURE

Check tire pressures on both the trailer and tow vehicle. Inflate to the value indicated on the trailer Certification/VIN label located on the left front side.

7 ACCESSORIES

7.1 WHEELCHAIR RAMP

Ramp can be installed on either side of trailer. The street side is illustrated in this procedure.

7.1.1 Install Ramp

1. To install ramp, remove lock pin and pin (A). Remove handrail (B). Repeat this step for other side handrail.

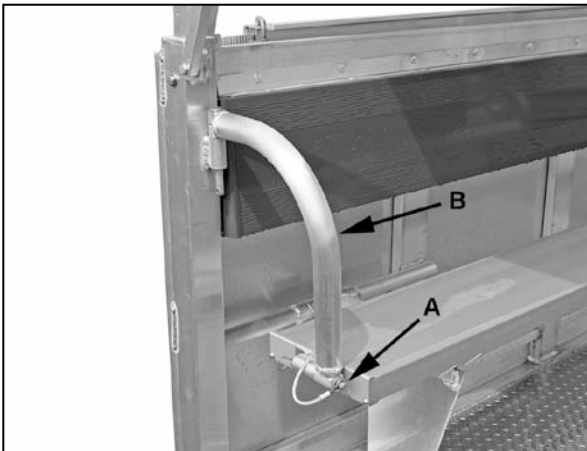

Remove Handrail - figure 7-1

2. Release latches (C) on front bench supports. Fold support brackets (D) and lower front bench.

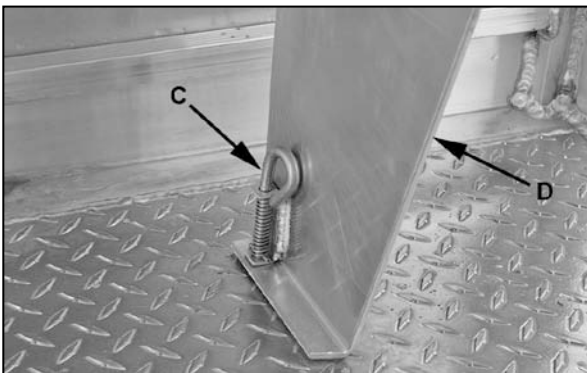

Release Latch - figure 7-2



Front Bench Folded Down - figure 7-3

3. Release latches (E) on ramp (F). Remove ramp from storage position.

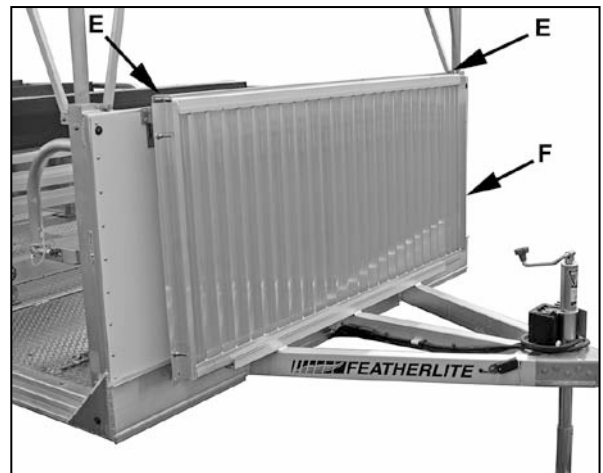

Storage Position - figure 7-4

4. Install pegs on ramp into holes in trailer side rail.



Install Ramp - figure 7-5

Section 7 - Accessories

5. Secure wheel chair to trailer anchors (G).

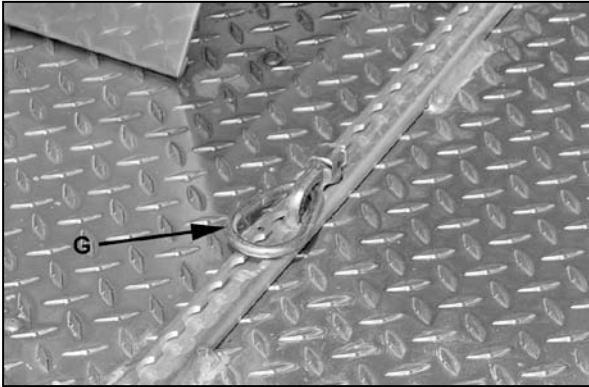

Wheelchair Anchor - figure 7-6

7.1.2 Remove and Stow Ramp

1. Remove ramp (F) and place in storage position on front of trailer.
2. Secure latches (E) to hold ramp in storage position.
3. Position front bench and secure latches (C) on bench supports.
4. Install both front handrails (B), pins (A) and lock pins.

8 INSPECTION, SERVICE & MAINTENANCE

8.1 INSPECTION, SERVICE & MAINTENANCE SUMMARY CHARTS

You must inspect, maintain and service your trailer regularly to insure safe and reliable operation. If you cannot or are unsure how to perform the items listed here, have your dealer do them. Note: In addition to this manual, also check the relevant component manufacturer's manual.

Featherlite Trailer Inspection and Service Intervals						
Item	Service Required	Manual Section Reference	Service Interval			
			Before Each Use	Every 3 Mo's	Every 6 Mo's	Every Year
Axle Attachment Bolts	Check by Featherlite dealer.	8.2.1				•
Breakaway Brakes	Check operation.	3.2.1.e, 3.2.2.d, 3.2.3.c	•			
Breakaway Battery	Fully charged, connections clean	8.2.3.c	•			
Breakaway Switch	Test operation, connections clean	8.2.3.c	•			
Brakes	Check operation.	8.2.3	•			
Shoes and Drums	Adjust.	8.2.3.c	First 200 mi., ea. 3,000 miles			
	Check for scoring and wear.				•	
Brakes						
Magnets	Inspect for wear and current draw.	Manufacturer	6 months or 6,000 miles			
Controller (in tow vehicle)	Check for correct amperage and modulation.	Manufacturer	6 months or 6,000 miles			
Coupler and Hitch Ball	Check for cracks, pits, flats. Replace w/ball & coupler having GVW. Grease. Check locking device & replace when worn.	8.2.4.a	•			

Section 8 - Inspection, Service & Maintenance

Featherlite Trailer Inspection and Service Intervals						
Item	Service Required	Manual Section Reference	Service Interval			
			Before Each Use	Every 3 Mo's	Every 6 Mo's	Every Year
Lights and Signals	Check for proper operation. Verify connection is clean and tight.	8.2.6	•			
Structure						
Trailer body	Wash as needed to remove salt and liquid de-icer	8.2.2				
Frame members	Inspect all frame members, bolts & rivets. Repair or replace damaged, worn or broken parts.	8.2.2.a				•
Welds	Inspect all welds. Repair as needed.	8.2.2.b				•
Tires						
	Check tire pressure when cold. Inflate as needed.	8.2.8	•			
	Rotate tires.		Every 5,000 miles			
	Inspect treads & sidewalls thoroughly. Replace tire when treads are worn or a sidewall has a bulge.	8.2.8		•		
Wheel Bearings (Hubs)						
Nev-R-Lube™ Bearings	Check for free running.	Manufacturer	Every 12,000 mi. or 1 yr.			
Lug Bolts and Hub	Check and tighten.	8.2.12	Check for tightness before every use. Check torque; After first 10, 25 & 50 miles; After any impact; Annually; & At start of towing season			
Rims	Inspect for cracks & dents. Replace as needed.	8.2.10	After any impact or 1 yr.			

8.2 INSPECTION AND SERVICE INSTRUCTIONS

8.2.1 Axle Bolts, Frame, Suspension, & Structure

⚠ WARNING

Worn or broken suspension parts can cause loss of control and injury may result.

Have trailer professionally inspected annually and after any impact.

To perform many of the inspection and maintenance activities, you must jack up the trailer. Figure 8-1 indicates the general areas where jacks and jack stands may be applied.

When jacking and using jack stands, place them so as to clear wiring, brake lines, and suspension parts

(springs, torsion bars, etc.). Place jacks and jack stands inside of the perimeter strip on the supporting structure to which the axles are attached.

⚠ WARNING

Never crawl under your trailer unless it is on firm and level ground and resting on properly placed and secured jack stands.

8.2.2 Trailer Structure

Wash the entire trailer thoroughly immediately after exposure to road salt and liquid deicer. The salt and liquid deicer will corrode and pit the aluminum.

8.2.2.a Fasteners and Frame Members

Inspect all of the fasteners and structural frame members for bending and other damage, cracks, or failure. Repair or replace any damaged fastener and

Section 8 - Inspection, Service & Maintenance

repair the frame member. If you have any questions about the condition or method of repair of fasteners or frame members, get the recommendation of, or have the repair done by, your dealer.

The various fastener types used on your trailer are:

- Bolts.
- Buck Rivets, which are used to attach the sides and roof panels of the body to each other, and to the frame of the trailer; and
- Huck Bolts may be at various locations on the sub-frame. Huck bolts are not user serviceable. If you detect a loose huck bolt fastener, do not tow the trailer. Call your dealer for instructions.

WARNING

Broken or damaged fasteners or welds can cause injury or damage to trailer and contents.

Inspect trailer before each use and repair or replace all damaged parts.

8.2.2.b Welds

All welds can crack or fail when subjected to heavy loads or movement of cargo that was not properly tied to prevent movement. Any time that you know or suspect that the trailer has been subjected to heavy loads or movement of cargo, immediately inspect the welds and fasteners for damage. To prevent severe damage to your trailer, inspect all of the welds for cracks or failure at least once a year.

WARNING

Do not attempt to repair a cracked or broken weld unless you have the skills and equipment to make a proper repair.

Improper weld repair will lead to early failure of the trailer structure and serious injury or death.

Go to your Featherlite dealer.

WARNING

Broken or damaged fasteners or welds can cause injury or damage to trailer and contents.

Inspect trailer before each use and repair or replace all damaged parts.

8.2.3 Trailer Brakes

8.2.3.a Initial Inspection

WARNING

Brakes that are out of adjustment can result in death or serious injury.

Brakes must be adjusted at the intervals specified.

The brake shoes must be adjusted after the first 200 miles of use, and each 3,000 miles thereafter.

Most axles are **not** fitted with a brake mechanism that will adjust the brakes. Brakes must be adjusted manually. It is critical that the brakes be adjusted at the specified intervals. Brakes that are out of adjustment can cause a collision, which may result in death or serious injury.

8.2.3.b Periodic Inspection

Properly functioning brake shoes and drums are essential to ensure safety. You must have your dealer inspect these components at least once per year, or each 12,000 miles.

8.2.3.c Manually Adjusting Brake Shoes

Some braking systems are not automatically adjusted by hard stopping. These brakes require manual adjustment. The following steps apply to adjust most manually adjustable brakes. Read your axle and brake manual to see how to adjust your brakes.

- Jack up the trailer and secure it on adequate capacity jack stands.
- Be sure the wheel and brake drum rotate freely.
- Remove the adjusting-hole cover from the adjusting slot on the bottom of the brake backing plate.
- With a screwdriver or standard adjusting tool, rotate the starwheel of the adjuster assembly to

Section 8 - Inspection, Service & Maintenance

expand the brake shoes. Adjust the brake shoes out until the pressure of the linings against the drum makes the wheel very difficult to turn.

- Note: Your trailer maybe equipped with drop spindle axles. See axle manual for your axle type. You will need a modified adjusting tool for adjusting the brakes in these axles. With drop spindle axles, a modified adjusting tool with about an 80 degree angle should be used.
- Rotate the starwheel in the opposite direction until the wheel turns freely with a slight drag.
- Replace the adjusting-hole cover.
- Repeat the above procedure on all brakes.
- Lower the trailer to the ground.

8.2.3.d Electric Brakes

Two different types of electric brakes may be present on the trailer: an emergency electric breakaway system, which acts only if the trailer comes loose from the hitch and the breakaway pin is pulled. The other brake is an electric braking system that acts whenever the brakes of the tow vehicle are applied.

Breakaway Battery

This battery supplies the power to operate the trailer brakes if the trailer uncouples from the tow vehicle. Be sure to check, maintain and replace the battery according to the battery manufacturer's instructions.

Breakaway Switch

This switch causes the breakaway battery to operate the electric brakes if the trailer uncouples from the tow vehicle.

The lanyard for the pull pin is connected to the tow vehicle, and the switch is connected to the trailer. To check for proper functioning of the switch, battery and brakes, you must pull the pin from the switch and confirm that the brakes apply to each wheel. You can do this by trying to pull the trailer with the tow vehicle, after pulling the pin. The trailer brakes may not lock, but you will notice that a greater force is needed to pull the trailer.

WARNING

If electric breakaway brakes do not operate when trailer is uncoupled from the tow vehicle, death or serious injury can occur.

Check emergency breakaway brake system BEFORE each tow.

Tow Vehicle Operated Electric Brakes

The electric brakes that operate in conjunction with the tow vehicle brakes must be "synchronized" so that braking is properly distributed to the tow vehicle brakes and the trailer brakes. For proper operation and synchronization, read and follow the axle/brake and the brake controller manufacturers' instructions. If you do not have these instructions, call Featherlite, Inc. at 800-800-1230 for assistance.

Magnets for all Electric Brakes

To make certain an electrically-operated braking system will function properly, you must have your dealer inspect the magnets at least once a year, or each 12,000 miles. See the brake manual for wear and current inspection instructions.

8.2.4 Trailer Hitch Coupler

The coupler on the trailer connects to the ball attached to the hitch on the tow vehicle. The coupler, ball and hitch transfer the towing forces between the tow vehicle and the trailer. Before each tow, coat the ball with a thin layer of automotive bearing grease to reduce wear and ensure proper operation; and check the locking device that secures the coupler to the ball for proper operation.

If you see or feel evidence of wear, such as flat spots, deformations, pitting or corrosion, on the ball or coupler, immediately have your dealer inspect them to determine the proper action to prevent possible failure of the ball and coupler system. All bent or broken coupler parts must be replaced before towing the trailer.

The coupler handle lever must be able to rotate freely and automatically snap into the latched position. Oil the pivot points, sliding surfaces, and spring ends with SAE 30W motor oil. Keep the ball pocket and latch mechanism clean. Dirt or

Section 8 - Inspection, Service & Maintenance

contamination can prevent proper operation of the latching mechanism.

When replacing a ball, the load rating must match or exceed the GVWR of the trailer.

8.2.5 Landing Leg or Jack

If a grease fitting is present, you must use a grease gun to lubricate the jack mechanism. Grease the gears in the top of hand-cranked jacks once a year, by removing the top of the jack and pumping or hand packing grease into the gears.

8.2.6 Lights and Signals

Before each tow, check the trailer taillights, stoplights, turn signals and any clearance lights for proper operation.

WARNING

To avoid collisions, taillights, stoplights and turn signals must work.

8.2.7 Tires

Before each tow, be sure the tire pressure is at the value indicated on the Certification / VIN label. Tire pressure must be checked while the tire is cold. Do not check the tire pressure immediately after towing the trailer. Allow at least three hours for a tire to cool, if the trailer has been towed for as much as one mile. Replace the tire before towing the trailer if the tire treads have less than 2/32 inch depth or the telltale bands are visible.

A bubble, cut or bulge in a side wall can result in a tire blowout. Inspect both side walls of each tire for any bubble, cut or bulge; and replace a damaged tire before towing the trailer.

WARNING

Worn, damaged or under-inflated tires can cause loss of control, injury and damage.
Check tires before each tow.

8.2.8 Wheel Rims

If the trailer has been struck, or impacted, on or near the wheels, or if the trailer has struck a curb, inspect the rims for damage (i.e. being out of round); and replace any damaged wheel. Inspect the wheels for damage every year, even if no obvious impact has occurred.

Never install aftermarket wheels or lug nuts on your trailer. Use only original equipment wheels and lugs nuts. Aftermarket wheels and lug nuts may not meet the load carrying requirements, pressure capacity and offset as the original equipment.

8.2.9 Wheel Bearings

A loose, worn or damaged wheel bearing is the most common cause of brakes that grab.

To check your bearings, jack trailer and check wheels for side-to-side looseness. If the wheels are loose, or spin with a wobble, the bearings must be serviced or replaced.

8.2.9.a Nev-R-Lube™ or Other Sealed Bearings

Bearing should be inspected every 12 months or 12,000 miles, whichever occurs first. Refer to the axle manufactures manual for information on checking wheel end play and clearance. See figure 8-7.

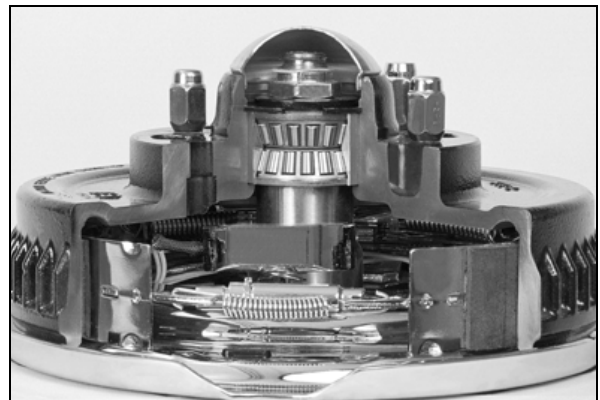

Nev-R-Lube™ Bearing Shown - Figure 8-1

8.2.10 Lug Nuts (Bolts)

Lug nuts are prone to loosen right after a wheel is mounted to a hub. When driving on a remounted wheel, check to see if the lug nuts are tight after the

Section 8 - Inspection, Service & Maintenance

first 10, 25 and 50 miles of driving and before each tow thereafter.

Lug Nut Tightening (Torque)

Being sure wheel mounting nuts (lug nuts) on trailer wheels are tight and properly torqued is an important responsibility that trailer owners and users need to be familiar with and practice. Inadequate and/or inappropriate wheel nut torque (tightness) is a major reason that lug nuts loosen in service. Loose lug nuts can rapidly lead to a wheel separation with potentially serious safety consequences.

- Be certain you have a clear understanding of the specific wheel maintenance responsibilities your vehicle manufacturer requires /recommends you, as the owner, must perform in order to insure your wheel equipment is safely maintained. Check the lug nut tightness the first 10, 25 and 50 miles of driving and before each tow thereafter. Refer to the owner's manual and speak with your dealer if you have any questions about proper tightening practices.
- The only way to be certain you have checked the tightness or torqued the lug nuts to the proper value is with a torque wrench. Four-way wrenches, ratchets, and similar tools can be useful for short-term emergency repairs but are not appropriate tools for accurately checking lug nut torque. You must use a torque wrench to accurately indicate the torque that you are applying to the lug nut.
- Keep a record of the date and approximate mileage when you check the lug nut torque. Note any lug nut that has lost torque. Investigate the reason(s) if the lug nut torque is not maintained after more than one re-torque application, because this indicates there is something wrong with the lug nuts, nut studs, wheels and/or hubs and should be corrected.
- Contact your dealer or vehicle manufacturer immediately if you experience any persistent lug nut loosening or any other lug, wheel or axle problems.
- In the event of a wheel separation incident, notify the vehicle manufacturer and dealer. Seek prompt professional assistance in assessing the trailer and its gear, and retain, but don't re-use involved lugs, wheels and studs. Don't repair or service the trailer yourself. Contact a trained technician.

WARNING

Lug nuts are prone to loosen after being first assembled. Death or serious injury can result.

Check lug nuts for tightness on a new trailer, and after re-mounting a wheel at 10, 25 and 50 miles.

WARNING

Metal creep between the wheel rim and lug nuts (bolts) will cause rim to loosen.

Death or injury can occur if wheel comes off.

Tighten lug nuts (bolts) before each tow.

Tighten the lug nuts to the proper tightness to prevent wheels from coming loose. Refer to the steps that follow and the axle manufacturer's information. Use a calibrated torque wrench to tighten the lug nuts. Over-tightening may result in breaking the studs or permanently deforming the mounting stud holes in the wheels.

Remove all excess paint, oil and grease from mounting surfaces.

Start all lug nuts by hand to prevent cross threading.

Tighten lug nuts in sequence shown in "Lug Nut Sequence of Tightening" figure 8-2.

Never install aftermarket wheels or lug nuts on your trailer. Use only original equipment wheels and lug nuts. Aftermarket wheels and lug nuts may not meet the load carrying requirements, pressure capacity and offset as the original equipment.

Never install aluminum wheels on hubs/studs that were designed for steel wheels. The stud length required for aluminum wheels is greater than that required for steel wheels.

Section 8 - Inspection, Service & Maintenance

⚠ WARNING

Aftermarket wheels may part from the trailer, resulting in death or serious injury.

Never install aftermarket wheels or lug nuts on your Featherlite trailer.

Never install aluminum wheels on hubs/studs that were designed for steel wheels.

⚠ WARNING

Information or torque values stamped on lug nuts supersedes the information listed in this manual.

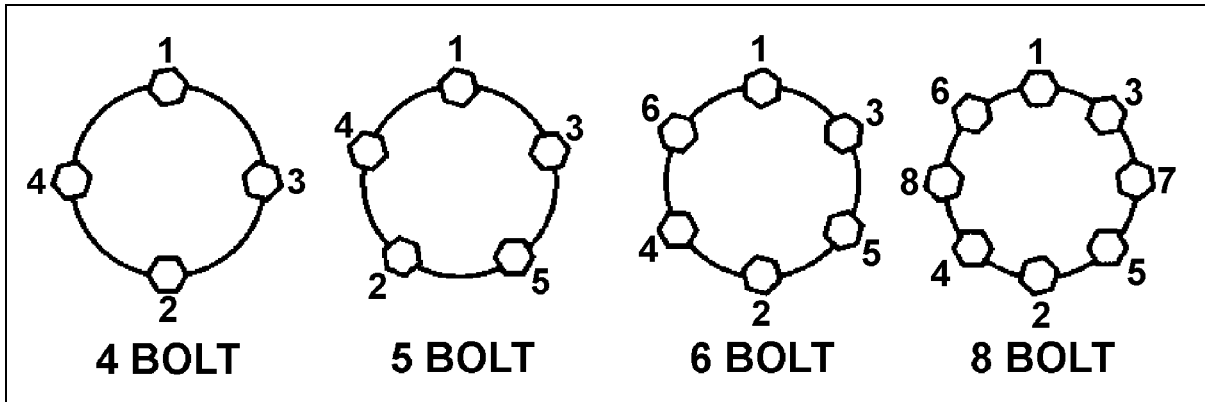

Lug Nut Sequence of Tightening - Figure 8-2

Lug Nut Torque			
Stud size	1st stage	2nd Stage	3rd Stage
1/2 Inch	35 lb ft	65 lb ft	100 lb ft
9/16 Inch	45 lb ft	90 lb ft	130 lb ft
5/8 Inch	70 lb ft	140 lb ft	200 lb ft
5/8 Inch Flanged	100 lb ft	200 lb ft	300 lb ft
3/4 Inch Flanged	135 lb ft	270 lb ft	400 lb ft

Lug Nut Torque - Figure 8-3

Lug nuts are prone to loosen right after a wheel is mounted to a hub. When driving on a remounted wheel, check to see if the lug nuts are tight after the first 10, 25 and 50 miles of driving and before each tow thereafter.

⚠ WARNING

Lug nuts are prone to loosen after being first assembled. Death or serious injury can result.

Check lug nuts for tightness on a new trailer, and after re-mounting a wheel at 10, 25 and 50 miles.

⚠ WARNING

Metal creep between the wheel rim and lug nuts (bolts) will cause rim to loosen.

Death or injury can occur if wheel comes off.

Tighten lug nuts (bolts) before each tow.

9 TECHNICAL REFERENCE

9.1 TRAILER LIGHTING ELECTRICAL CONNECTION

The electrical wiring on your Featherlite trailer has been designed and built in accordance with all the Federal Motor Vehicle Safety Standards that were in effect when the trailer was produced.

The figure below illustrates the wiring code that has been adopted for several types of electrical lighting connectors.

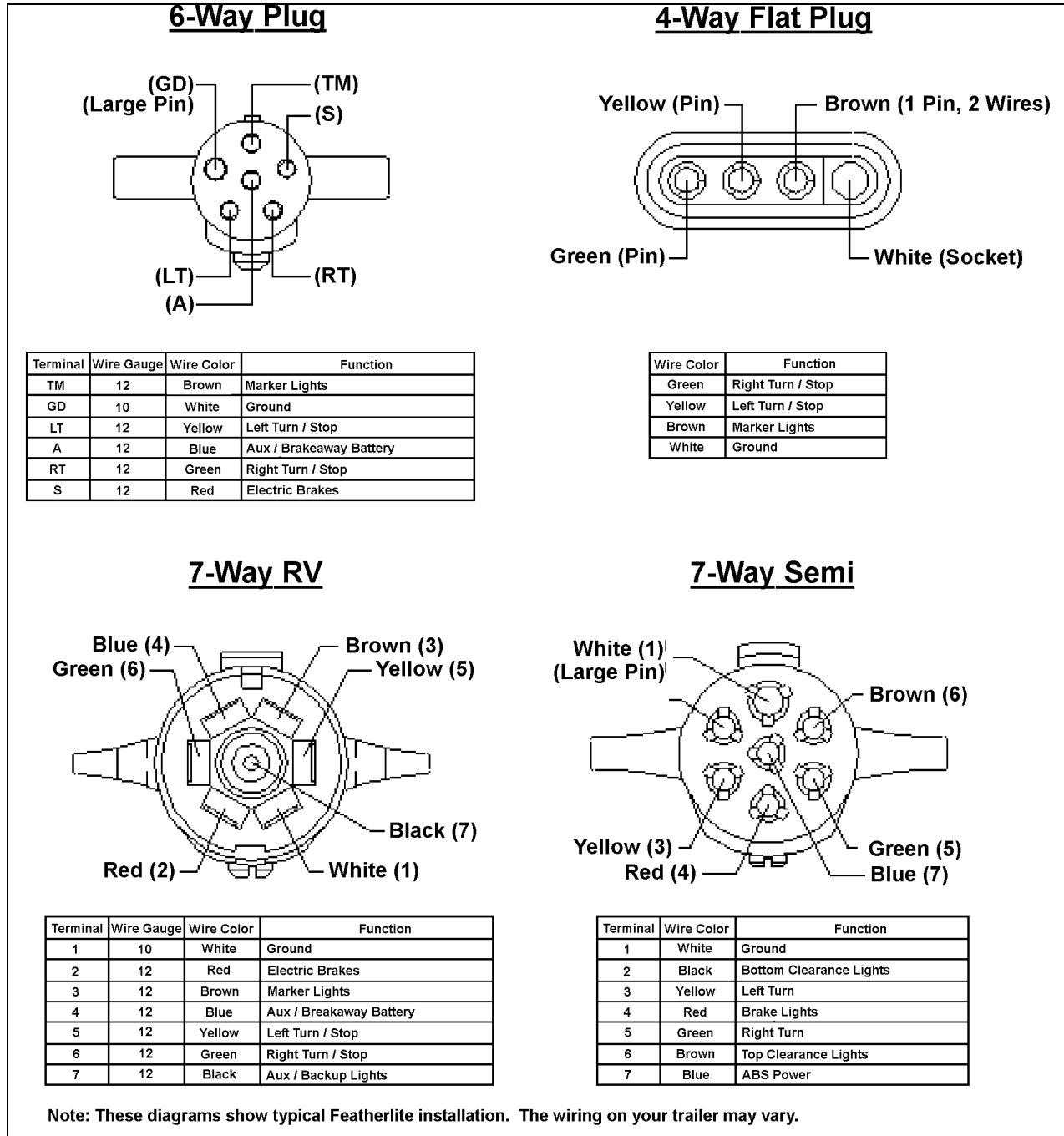

Trailer Lighting Electrical Connection - Figure 9-1

Section 9 - Technical Reference

9.2 HITCH SYSTEMS

The various components of trailer fastening systems may be referred to in terms of “Class” depending on their load rating. The rating of hitch systems on tow vehicles also considers whether the hitch only carries the tongue weight (for example, a ball hitch, which is also referred to as a Weight Carrying Hitch), or if it distributes the tongue weight to all of the tow vehicle wheels (also referred to as a Weight Distributing Hitch).

Your hitch or hitch ball may carry a “class” rating instead of a pound rating. This chart may be used to cross reference hitch/ball classification with trailer weight and tongue weight.

Hitch Classification

Class	Type of Hitch	Maximum Towed Weight	Maximum Tongue Weight
Class 1	Weight Carrying Hitch	up to 2,000 pounds	up to 200 pounds
Class 1	Weight Dist. Hitch	up to 2,000 pounds	up to 300 pounds
Class 2	Weight Carrying Hitch	up to 3,500 pounds	up to 300 pounds
Class 2	Weight Dist. Hitch	up to 3,500 pounds	up to 500 pounds
Class 3	Weight Carrying Hitch	up to 5,000 pounds	300 to 500 pounds
Class 3	Weight Dist. Hitch	up to 7,500 pounds	up to 750 pounds
Class 4	Weight Dist. Hitch	up to 10,000 pounds	up to 1,000 pounds



Featherlite Apparel **GREAT LOOKS! GREAT FEEL! GREAT PRICE!**

Call Toll Free: 800-800-1230 | Shop Online: www.featherlitewear.com

Apparel availability subject to change



Repair Parts & Accessories **LOCAL DEALERS! LOCAL SALES! LOCAL SERVICE!**

Repair Parts can be obtained from the Featherlite dealer serving your area. Call your local dealer for parts & accessories for your trailer or contact our corporate office and ask for Dealer Information.

Call Toll Free: 800.800.1230 | Web: www.fthr.com (search dealer locator)

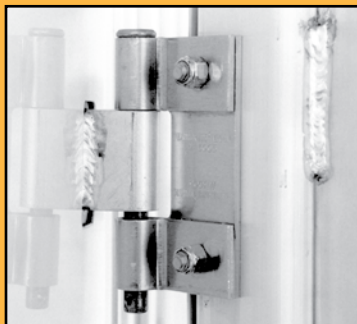



toll free 800.800.1230 | fax 563.547.6100 | email salesinfo@fthr.com
web www.fthr.com | address Hwy. 63 & 9, PO Box 320, Cresco, IA 52136



PROUD MEMBER

FEATHERLITE MANUFACTURES:

Horse Trailers
Livestock Trailers
Open Car Haulers
Custom Interiors
Concession Trailers
Motorcycle Trailers
Snowmobile Trailers
Enclosed Car Haulers
Living Quarters Trailers
Display Trailers
Semi Livestock Trailers
Vending Trailers
Hospitality Trailers
Kitchen Trailers
Utility Trailers
Truck Beds
Transporters
Living Quarters
Dry Freight Trailers
Specialty Trailers
Drop Frame Vans