



OWNER'S MANUAL

LIVING QUARTERS





Thank You... From Featherlite Trailers

Dear Customer,

Thank you for purchasing a Featherlite Trailer.

You are now part of tens of thousands in North America who enjoy Featherlite Trailers for their premium grade construction, innovative features and custom interiors. Featherlite builds hundreds of different standard and custom-designed aluminum specialty trailers and transporters. For each and every one, customer satisfaction is Featherlite's passion and safety is top priority.

Featherlite knows the most important thing that goes into each and every trailer is what you, our customer, put in it. That is why the features of all Featherlite trailers are engineered with the customer and the cargo in mind.

Please know that Featherlite's dedicated dealers and employees are here for you. Let Featherlite know how we can be of service now and in the future.

Thanks again and best wishes!

Featherlite Trailers

P.S. Keep current on Featherlite's innovative new trailers at www.fthr.com.

THANK YOU FOR CHOOSING FEATHERLITE!



CONTENTS

1. Introduction.....	2	6.5.2 Disconnect Shore Power	19
1.1 Driving Characteristics.....	2	6.6 Generator	19
1.2 Customer Service	2	6.6.1 Starting Generator.....	20
2. Safety	3	6.6.2 Stopping Generator.....	20
2.1 Safety Symbols And Signal Words	3	7. Slideout	21
2.2 Hazards From Accessories	3	8. Electrical Appliances	22
2.3 Carbon Monoxide (CO) Hazard.....	3	8.1 General Information.....	22
2.4 LP Gas Appliance Hazards.....	4	8.2 Air Conditioning.....	22
2.5 Electrical Hazards	6	8.2.1 Thermostat.....	22
2.5.1 Generator	6	8.2.2 Maintenance.....	22
2.5.2 Shore Power.....	6	8.3 Exhaust Hood.....	22
2.6 Mechanical Hazards.....	6	8.4 Microwave Oven.....	22
2.6.1 Roof Antenna	6	8.5 Cook Top.....	22
2.6.2 Slideout	6	9. Gas Appliances.....	23
2.7 Indoor Air Quality.....	6	9.1 Carbon Monoxide (CO) Hazard.....	23
2.7.1 Humidity And Condensation	6	9.2 LP Gas Appliance Hazards.....	23
2.7.2 Mold And Mildew	7	9.3 Water Heater	24
2.7.3 Formaldehyde.....	7	9.4 Furnace	25
2.8 Safety Warning Labels.....	7	9.5 Cook Top.....	25
3. Safety Devices	10	9.6 Refrigerator	26
3.1 Carbon Monoxide/LP Gas Detector.....	10	10. Interior Furnishings.....	27
3.2 Smoke Detector.....	10	10.1 Roof Vent	27
3.3 Fire Extinguisher.....	11	10.2 Sofa/Bed Conversion.....	27
3.4 Egress Window	11	10.3 Dinette/Bed Conversion	27
4. Water System.....	12	11. Awning.....	28
4.1 Potable Water Supply	12	12. Storage And Winterizing.....	29
4.2 External Water Supply	12	12.1 Preparing Trailer For Storage	29
4.3 Disinfection/Sanitation	12	12.2 Winterizing.....	29
4.4 Fill Potable Water Tank.....	13	13. Interior Care	32
4.5 Water Pump	13	13.1 Carpet.....	32
4.6 Priming Water System	13	13.2 Upholstery	32
4.7 Toilet.....	14	13.3 Vinyl.....	32
4.8 Drain Waste Tanks	14	13.4 Cabinets.....	32
4.9 Tank Heaters.....	14	13.5 Tables And Counter Tops	32
5. Liquefied Petroleum (LP) Gas System ..	15	13.6 Stainless Steel Sink.....	32
5.1 Traveling With LP Gas	16	13.7 Bathroom	32
5.2 Using LP Gas In Winter	16	14. Maintenance And Inspections.....	33
5.3 Regulator	16		
6. Electrical Systems.....	17		
6.1 Power Converter	17		
6.2 Charging Circuit.....	17		
6.3 120/240 Volt Circuits	17		
6.4 12 Volt Circuits	18		
6.5 Shore Power	18		
6.5.1 Connect Shore Power	18		



1. INTRODUCTION

This manual covers the living quarters in your trailer. A separate manual covers the basic trailer operation.

This manual was prepared to provide you with the information to properly operate and maintain the items that pertain to the living quarters in your trailer.

Read this manual before using your trailer and follow all of the safety precautions and instructions. One manual cannot cover the trailer and all of the accessories installed in your trailer. Refer to the trailer owner's manual, this manual and the Operator's Manual for each accessory installed in your trailer for safety, operational and maintenance information.

Please keep this and all other manuals inside your trailer at all times.

1.1 DRIVING CHARACTERISTICS

A trailer with a living quarters is heavier than one without a living quarters. A heavier trailer requires more time to stop, more distance to accelerate, and turning must be done at slower speeds.

1.2 CUSTOMER SERVICE

If you need additional information or assistance, contact your trailer dealer.

2. SAFETY

2.1 SAFETY SYMBOLS AND SIGNAL WORDS

Our trailers are built with components produced by various manufacturers. Some of these items have separate instruction manuals. Where this manual indicates that you should read another manual, and you do not have that manual, call Featherlite, Inc. at 800-800-1230.

The safety information in this manual is denoted by the safety alert symbol: 

The level of risk is indicated by the following signal words.

 DANGER
Immediate hazards which WILL result in death or serious injury if the warning is ignored.

 WARNING
Hazards or unsafe practices which COULD result in death or serious injury if the warning is ignored.

 CAUTION
Hazards or unsafe practices which could result in minor or moderate injury if the warning is ignored.

NOTICE
Hazards which could result in equipment or property damage.

2.2 HAZARDS FROM ACCESSORIES

This manual contains information on accessories that may be installed in your trailer.

You must read the instruction manual for each accessory before operating them. Follow all instructions and warnings in those manuals and in this manual.

The primary hazards from operation of accessories are:

- Death by carbon monoxide poisoning from operation of:
 - Generator.
 - LP gas appliances.

- Fire or explosion from accumulated, unburned LP gas.
- Electrocution or fire from generator or shore power.
- Crushing from slideout operation.

2.3 CARBON MONOXIDE (CO) HAZARD

Carbon monoxide can come from operation of fuel burning appliances such as a generator, water heater, furnace, cook top and oven. Never operate any of these appliances while the trailer is in an enclosed building or confined area.

Carbon monoxide is a colorless, tasteless, odorless gas that can cause brain damage or death.

Symptoms of carbon monoxide poisoning are:

- Headache
- Drowsiness
- Nausea
- Vomiting
- Shortness of breath
- Unconsciousness

If any of these symptoms exist, remove the victim immediately to fresh air and get medical attention.

Never operate a portable fuel burning appliance inside trailer. Deadly carbon monoxide is produced by these appliances.

 DANGER
You can die or be brain damaged by carbon monoxide.
Do not operate gas appliances or generator while trailer is in an enclosed building or confined area.
Test carbon monoxide detector for operation before operating any gas appliances or generator.

Never use a cooking appliance to provide comfort heating.



⚠ WARNING

Carbon monoxide poisoning or fire hazard.

The fumes from burning gas contain carbon monoxide, an odorless gas that can cause death or brain damage.

Cooking appliances used for comfort heating can ignite surrounding surfaces.

It is not safe to use cooking appliances for comfort heating.

Never operate any gas burning appliances while trailer is in an enclosed building or confined area. A confined area will not allow proper ventilation and carbon monoxide fumes can enter trailer.

Conditions that can redirect carbon monoxide fumes are for example:

- Being drawn in by fans or ventilators operated in a trailer.
- Prevailing wind.
- Being trapped between adjacent trailers, vehicles or buildings.
- Being trapped between or in a snow bank or other materials that can redirect fumes.

You must have a working carbon monoxide detector in the living space of trailer.

Test carbon monoxide detector after periods of storage, before each trip, or before operating any gas burning appliance.

A blocked appliance vent can cause a fire or result in carbon monoxide entering into trailer.

Check the following appliance vents for debris after periods of storage and before each use:

- Furnace
- Water Heater
- Exhaust Hood

Turn exhaust hood on before lighting cook top burners or oven to vent fumes and cooking odors outside.

2.4 LP GAS APPLIANCE HAZARDS

Your trailer may be equipped with the following appliances that operate on LP gas:

- Cook top
- Oven
- Water heater
- Refrigerator
- Furnace

Keep LP gas cylinder supply valves closed at all times, except when using a gas appliance.

LP gas system in trailer is designed to operate on LP gas only, NOT natural gas. A natural gas supply is not safe for use in an LP gas system.

⚠ WARNING

Prevent explosion or fire.

Connect LP gas system to a supply of LP gas only, NOT natural gas.

Do not place a LP gas cylinder inside trailer.

Have LP gas cylinder refilled by a qualified LP gas supplier.

Verify all LP gas appliances are off before opening LP gas cylinder supply valves. If an appliance is left on, gas could accumulate in trailer creating a fire or explosion hazard.

⚠ WARNING

Explosion hazard.

Gas can accumulate in the trailer if an appliance control is left on and the gas supply valve is opened.

Verify that all appliance controls are off before opening gas supply valve.

Do not attempt to fill LP gas cylinders yourself. Have cylinders filled by a qualified LP gas supplier.

Turn off all gas appliances and pilot lights before refueling LP gas cylinders, gasoline or diesel fuel tanks, and when towing trailer. Some automatic ignition appliances may continue to spark after gas is turned off at supply valve.

⚠ WARNING

Fire and explosion hazard.

If LP gas is detected (by smell or by the LP gas detector):

- Do not touch electrical switches.
- Extinguish flames and pilot lights.
- Shut off gas supply at LP cylinders.
- Leave the area until odor clears.

Have a qualified LP gas technician correct the source of gas leakage before using LP appliances.

Do not use a flame to locate the source of a gas leak.

⚠ WARNING

Fire and explosion hazard.

Automatic ignition appliances may continue to spark after gas supply valves are turned off, which can ignite gas fumes.

Turn off all gas appliances and pilot lights when refueling gasoline or diesel tanks, LP gas tanks, or when towing trailer.

⚠ WARNING

Fire and explosion hazard.

Cooking appliances used for comfort heating can ignite surrounding surfaces.

It is not safe to use cooking appliances for comfort heating.

⚠ WARNING

Fire and explosion hazard.

Light one burner at a time.

If any burner goes out after lighting, turn off all burners and wait five minutes before relighting.

Turn controls off when not in use and while refueling.

Do not store or use flammable vapors or liquids near this or any other appliance.

⚠ WARNING

Fire and explosion hazard.

Do not store or use flammable vapors or liquids near any appliance.

If water heater overheats, turn off LP gas cylinder supply valves.

Turn off all gas appliances and pilot lights when refueling gasoline or diesel tanks, LP gas cylinders or when towing trailer.



2.5 ELECTRICAL HAZARDS

Trailer is equipped with a 120 or 240 volt electrical system. The electricity for this system can be provided by the shore power cord or a generator.

Shore power and a generator pose a risk of death due to electrocution or fire.

Replace fuses and circuit breakers with the correct rating.

2.5.1 GENERATOR

If your trailer is equipped with a generator, you must have and follow the generator manufacturers instructions.

⚠ WARNING

Operating a gasoline or diesel generator can lead to death or serious injury by:

- Carbon Monoxide
- Fire and Explosion
- Electrocution

Have a working carbon monoxide detector in the living space of trailer before operating generator.

Do not refuel a running generator or refuel near ignition sources.

Generator can be started from a remote switch.

2.5.2 SHORE POWER

⚠ WARNING

Electrocution or fire hazard.

Always use cord that was supplied with trailer when manufactured or a Featherlite approved replacement. Never use an extension cord.

Always connect electrical cord to a grounded source of shore power.

Never remove prongs from shore power plug.

Connect only to source of proper voltage.

2.6 MECHANICAL HAZARDS

2.6.1 ROOF ANTENNA

⚠ WARNING

Electrocution hazard.

Antenna contacting power lines can cause electrocution.

Be sure there are no power lines over or near trailer before raising antenna.

2.6.2 SLIDEOUT

⚠ WARNING

Crushing hazard.

People can be crushed by the extending or retracting slideout.

The pinch areas around outside perimeter can crush and sever limbs.

Keep people away from the inside and outside of slideout while extending

2.7 INDOOR AIR QUALITY

⚠ CAUTION

This living quarters was designed for short term recreational occupancy.

Prolonged occupancy can lead to premature component wear and/or failure and create conditions, which if not managed properly, may be hazardous to your health and/or cause significant damage to your living quarters.

2.7.1 HUMIDITY AND CONDENSATION

Humidity or moisture generated by bathing, cooking, and normal breathing can increase interior humidity levels. Unless the moisture is carried outside by ventilation or condensed by a dehumidifier or air conditioner, it will condense inside the living quarters.

Extreme situations may result in condensation or water dripping from the ceiling and other interior surfaces.

Following guidelines below will help reduce excessive condensation.

- Use roof vent during shower use.
- Use range hood vent while cooking.
- Do not hang wet clothes inside to dry.
- During warm weather, use air conditioner to remove humidity and lower indoor temperature. Use a dehumidifier if necessary.
- Allow air to circulate inside closets and cabinets.
- Open roof vent or window if exterior air is less humid than interior air.
- Avoid excessive changes in thermostat settings.
- Use the least amount of water possible when cleaning interior.
- Maintain exterior sealants.
- Open vent or window slightly when storing trailer.
- Immediately clean and dry all water spills or leaks inside trailer.

Failure to control excessive humidity can result in damage which is not covered by warranty.

It is recommended the humidity levels be monitored with a basic hygrometer.

2.7.2 MOLD AND MILDEW

Mold can break down materials such as fabric, wood and similar products, and some individuals experience allergic reactions to certain types of mold.

Mold prefers high humidity conditions in temperatures between 40 - 100°F. Management of humidity and temperature levels will reduce mold growth.

Mold growth may be reduced by performing suggested procedures listed in section 2.7.1.

Immediate clean up of water spill, maintaining a clean environment, reduction of humidity, use of air conditioner, use of mold killing cleaner on safe surfaces, and wiping damp walls of shower after use, will help to reduce growth or spread of mold.

2.7.3 FORMALDEHYDE

⚠ WARNING
Do not smoke inside trailer.
Tobacco smoke releases formaldehyde and other air pollutants.

Formaldehyde may be released from smoking, cooking, soaps, detergents and many other household products.

Formaldehyde is also a by-product of combustion and certain other natural processes.

Ventilating trailer will substantially reduce any build-up of formaldehyde. Ventilate trailer during periods of high temperatures and high humidity. Also ventilate trailer when first using a new trailer.

To ventilate trailer, open window(s) and open a roof vent or turn on a roof fan.

2.8 SAFETY WARNING LABELS

⚠ WARNING
To protect you and others against death or serious injury, all of the labels shown must be on the trailer and must be legible.
If any of these labels are missing or cannot be read, contact Featherlite Parts Department at 800-800-1230, option #2 between the hours of 8:00 - 5:00 CST for replacement labels.

⚠ WARNING
Do not store combustible material in this area.
May cause a fire, which could result in death or serious injury.

Located On Water Heater Compartment Door

⚠ DANGER

All pilot lights, appliances and their igniters (see operating instructions) shall be turned off before refueling of motor fuel tanks and/or propane containers. May cause ignition of flammable vapors, which can lead to a fire or explosion and result in death or serious injury.

⚠ WARNING

Do not fill propane container(s) to more than 80 percent of capacity. A properly filled container contains approximately 80 percent of its volume as liquid propane.

Overfilling the propane container(s) can result in uncontrolled propane flow, which could lead to a fire or explosion and result in death or serious injury.

⚠ WARNING

This propane piping system is designed for use with propane only. Do not connect natural gas to this system. Securely cap inlet when not connected for use. After turning on propane, except after normal cylinder replacement, test propane piping and connections to appliances for leakage with soapy water or bubble solution. Do not use products that contain ammonia or chlorine to test for leaks. May lead to a fire or explosion, which could result in death or serious injury.

Located Near LP Tanks

⚠ DANGER

IF YOU SMELL PROPANE

1. Extinguish any open flames and all smoking materials.
2. Shut off the propane supply at the container valve(s) or propane supply connection.
3. Do not touch electrical switches.
4. Open doors and other ventilating openings.
5. Leave the area until the odor clears.
6. Have the propane system checked and leakage source corrected before using again.

Ignition of flammable vapors could lead to a fire or explosion and result in death or serious injury.

Located Near Cook Top

⚠ DANGER

Do not use gas cooking appliances for comfort heating.

May lead to carbon monoxide poisoning, which can lead to death or serious injury.

⚠ WARNING

Gas cooking appliances need fresh air for safe operation.

Before operating:

Open vents or windows slightly or turn on exhaust fan prior to using cooking appliance.

Gas flames consume oxygen, which should be replaced to ensure proper combustion.

Improper use may result in death or serious injury.

Located Near Cook Top

⚠ WARNING

Potable water only. Sanitize, flush, and drain water tank before using.

See owner's manual for instructions, care, and maintenance information.

Failure to maintain tank may result in death or serious injury.

Located Near Water Connectors

⚠ WARNING

Test smoke alarm operation after vehicle has been in storage, before each trip, and at least once per week during use. Failure to do so may result in death or serious injury.

Located Near Smoke Detector

EXIT

Located On Egress Window And Above Door



3. SAFETY DEVICES

Trailer is equipped with a:

- Carbon monoxide detector
- LP gas leak detector
- Smoke detector
- Fire extinguisher.

Test each of the detectors and verify the fire extinguisher is functional after periods of storage, before each trip, or at least once per week.

3.1 CARBON MONOXIDE/LP GAS DETECTOR

⚠ DANGER

You can die or be brain damaged by carbon monoxide.

Do not operate gas appliances or generator without a working carbon monoxide detector.

Test carbon monoxide detector for operation before operating any gas appliances or generator.

The carbon monoxide/LP gas detector operates off of the trailer 12 volt battery. Press test/mute button (A) until alarm sounds, then release. If alarm does not sound, contact your Featherlite dealer before using any gas appliance.

Refer to the Owner's Manual provided with your carbon monoxide/LP gas detector for additional safety, operating and maintenance information.

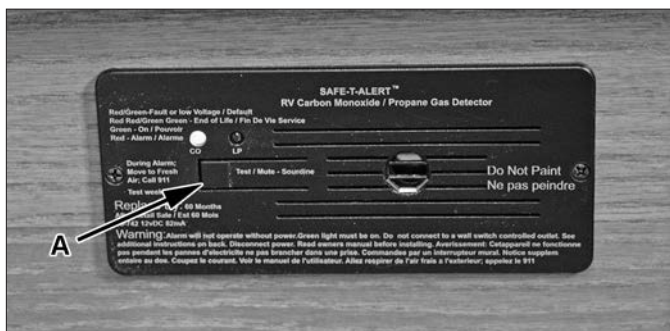

3.2 SMOKE DETECTOR

⚠ WARNING

Risk of death from smoke inhalation or fire.

Do not use trailer living space without a working smoke detector.

Test smoke detector:

- After periods of storage.
- Before each trip.
- At least once per week.

Replace smoke detector battery at least once every year.

Press test button (A) until alarm sounds, then release. If alarm does not sound, replace batteries and retest. If detector still does not work, replace it before using the trailer.

Refer to the Owner's Manual provided for your smoke detector for additional safety, operating and maintenance information.



3.3 FIRE EXTINGUISHER

Refer to Owner's Manual provided for your fire extinguisher for recommended replacement, recharging information, safety, operating and maintenance information.



3.4 EGRESS WINDOW

Emergency egress window is designed to allow emergency exit during an emergency if access to main entrance door is not available. This window are identified by an exit label and also red handles or latches.

To open, rotate handles (1) push window outward.





4. WATER SYSTEM

NOTICE

Prevent equipment damage.

Appliances and plumbing can be damaged by temperatures below 32° F.

Drain water system and winterize if trailer will be subjected to temperatures below 32° F.

4.1 POTABLE WATER SUPPLY

Trailer is equipped with a potable water system. It provides fresh water to kitchen, lavatory, toilet and shower. Water is supplied by either the potable water storage tank, or by an external water source.

4.2 EXTERNAL WATER SUPPLY

Any pressurized external water supply connected to the water system bypasses the demand pump and potable water storage tank, supplying water directly to all faucets and toilet. There is a check valve on demand pump that prevents external water supply from filling potable water storage tank.

External water connection has a regulator that allows the system to be connected to a high pressure water supply. The regulator keeps the water pressure in the trailer at 30 psi.

Connect To External Water Supply

1. Move demand pump switch (A) to Off position.

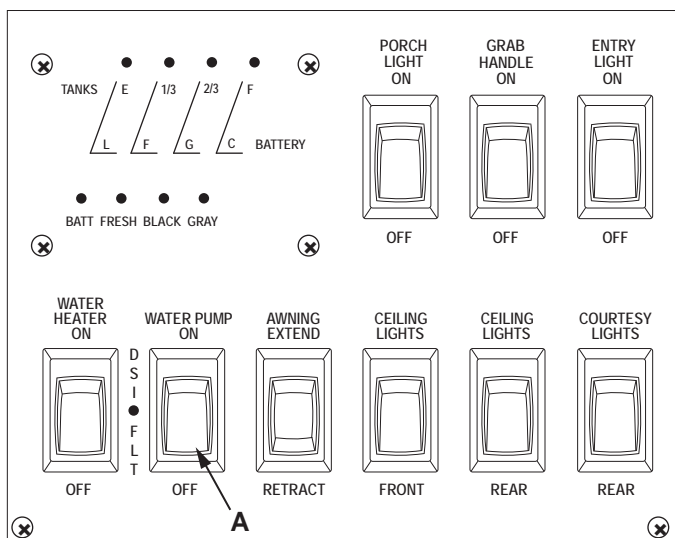

Note: Always make sure you are connecting to an approved potable water source, or a source you know is safe.

2. Attach potable water hose to connector (B) on side of trailer.



Disconnect External Water Supply

1. Turn off external water supply.
2. Open a faucet inside trailer to relieve pressure in water lines.
3. Disconnect potable water hose and install cover on connection (B).

4.3 DISINFECTION/SANITATION

Disinfect potable water tank before use. Disinfection is required immediately after periods of storage and every six months.

1. Prepare a chlorine solution using 1 gallon of water and 1/3 cup household bleach (sodium hypochlorite solution). Prepare 1 gallon of chlorine solution for every 15 gallons of tank capacity. This will result in a residual chlorine concentration of 50 parts per million (ppm).
2. With tank empty, pour chlorine solution into water tank. Complete filling of tank with fresh water. Open each faucet and run water until a distinct odor of chlorine can be detected in water discharge.
3. Turn off faucet as soon as chlorine is smelled.
4. Allow system to stand at least 4 hours when disinfecting with 50 ppm residual chlorine. Disinfection will not occur if 50 ppm solution is removed before the 4 hour time period. If a shorter time period is desired, use a 100 ppm chlorine concentration in system for

at least one hour. Disinfection will not occur if the 100 ppm solution is removed before the 1 hour time period. To mix a 100 ppm concentration, use 1/2 cup of household bleach with 1 gallon of water to prepare chlorine solution.

5. Drain water tank at a recreational vehicle waste dumping facility and flush tank with fresh potable water.

4.4 FILL POTABLE WATER TANK

Note: Always make sure you are filling the potable water storage tank from an approved potable water source, or a source you know is safe.

1. Open cap on potable tank connector (A) and insert a potable water hose. Tank has built in overflow valves and vents to prevent air from being locked inside.

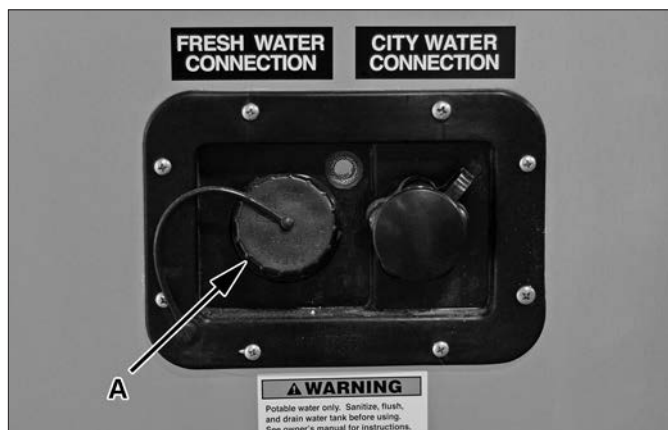

2. Open water supply to fill tank.
3. Display indicates water level in fresh water tank, waste tanks and 12 volt battery level. Press and hold respective switch (B), and lamps (C) indicate level. To get an accurate battery level reading, the trailer must be disconnected from shore power, or the power converter and all 12 volt loads turned off.

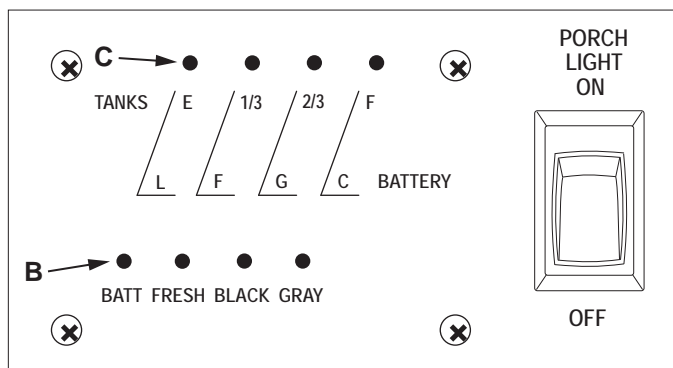

4.5 WATER PUMP

To use the self-contained potable water storage tank, pressure is supplied by a water pump. Pump is fully automatic and will run when a faucet is opened or toilet is flushed after initial priming. Move water pump switch (A) to On position. Pump will operate only if this switch is on.

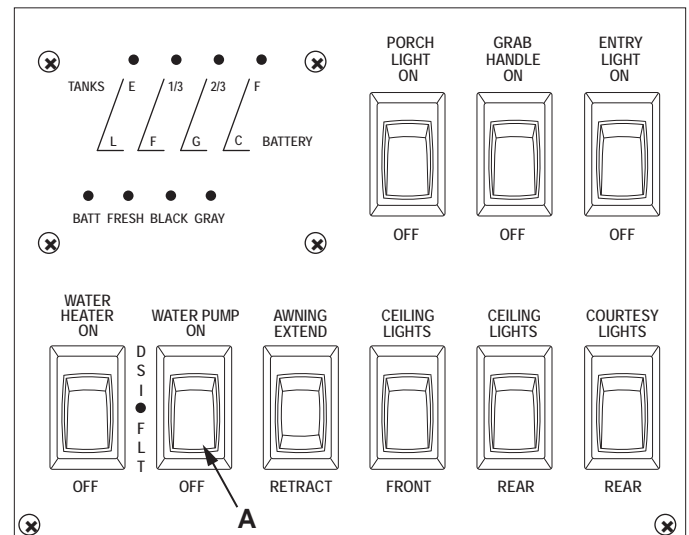

When water system is not in use, or when trailer will be unattended for an extended period of time, move water pump switch to the Off position. If there is a slow leak or a faucet is left partially open, pump could drain entire tank and discharge battery.

4.6 PRIMING WATER SYSTEM

Using The Potable Water Storage Tank

1. Verify all water drain valves are closed including the water heater.
2. Verify water pump switch is in Off position and water tank is full.
3. Open all faucets.
4. Turn the demand pump on.
5. Close each faucet as it begins to run a steady stream of water. Turn the hot water faucet off last to ensure water heater tank is filled.
6. After all faucets are primed and shut, check the demand pump to ensure that it has stopped. If the pump continues to run, check for an open faucet or leaks.
7. Water system is now ready for automatic operation. The pump will start automatically when a faucet is opened or the toilet is flushed.

Using An External Water Supply

1. Verify all water drain valves are closed, including water heater valve.
2. Verify water pump switch is in Off position and external water supply hose is connected.
3. Open all faucets.
4. Turn water supply on.
5. Close each faucet as it begins to run a steady stream of water.
6. Turn hot water faucet off last to ensure water heater tank is filled.
7. Water system is now ready for use.

4.7 TOILET

1. Operate toilet flush lever to add water to toilet until desired water level is reached. More water is generally needed to flush solids.
2. Push down on flush lever until contents leave the bowl. This may require holding flush lever down for several seconds.
3. Release flush lever by allowing it to snap back. This will ensure a positive seal. A small amount of water will remain in bowl.

4.8 DRAIN WASTE TANKS

1. Remove drain hose from holding tube.
2. Remove cap (A) and connect drain hose to connector.
3. Pull out on large drain line handle (B) first to drain sewage (black) tank. Only open one valve at a time.
4. Push in to close after draining.
5. Pull out on small drain line handle (C) to drain waste water (gray) tank. Draining this tank last will flush out the drain hose. Push in to close valve after draining.
6. Remove drain hose, rinse and place in storage tube.
7. Install cap (A).

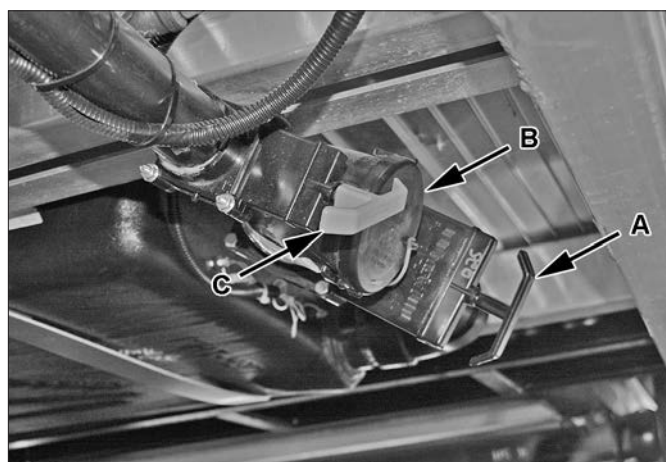

4.9 TANK HEATERS

Trailer may be equipped with tank heaters to help prevent tanks from freezing in cold weather. Heaters are 120 volt and can be used while connected to shore power or while generator is running. Press top of respective switch to turn heater on.

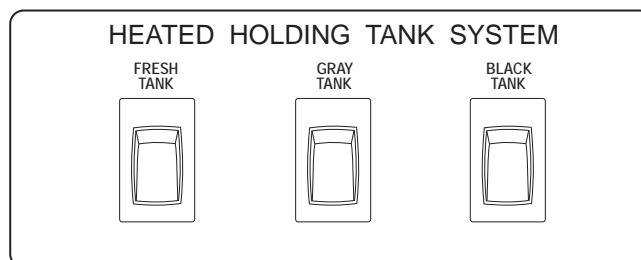

5. LIQUEFIED PETROLEUM (LP) GAS SYSTEM

The LP gas system installed in the trailer can operate an oven, cook top, refrigerator, water heater, generator and furnace.

The fumes from burning LP gas contain carbon monoxide, an odorless and colorless gas that can cause death or brain damage.

Do not operate any gas appliance unless the carbon monoxide/LP gas detector is working.

The exhaust hood must be turned on while using a gas cook top and oven.

NEVER use the cook top or oven for comfort heating.

NEVER operate a portable grill, portable stove, portable heater or portable gas lantern inside the trailer.

NEVER leave gas appliances on while the trailer is being towed.

NEVER leave gas appliances on while refueling the tow vehicle.

DANGER

Carbon monoxide poisoning and fire hazard.

Do not operate LP gas appliances while trailer is in an enclosed building or confined area.

Do not use cooking appliances for comfort heating. Flame could ignite surrounding surfaces and fumes contain carbon monoxide.

Test carbon monoxide/LP gas detector for operation before operating any gas appliances.

Unburned LP gas can create an explosive mixture where a spark or open flame can set off an explosion. To prevent accumulation of unburned LP gas:

- Turn appliances off when not in use.
- Turn LP gas cylinder supply valves off when trailer is not being used.

- Turn all appliances off before opening LP gas cylinder supply valves.
- Verify proper operation of carbon monoxide/LP gas detector.

WARNING

Explosion or fire hazard.

LP gas cylinders can discharge gas to the atmosphere as air temperature changes.

Never place a LP gas cylinder inside trailer.

The LP gas system in your trailer is designed to operate on LP only, NOT natural gas. A natural gas supply is not safe for use in an LP system due to the difference in the gas pressure, which will result in an uncontrollable flame.

WARNING

Explosion or fire hazard.

LP gas system is not compatible with natural gas.

Do not connect LP gas system to a natural gas fuel source.

If you are having trouble keeping appliances lit or lighting them, there may be air in LP gas system. Air in system will mix with gas vapors causing gas to burn poorly. This is common when LP gas system is first used or after an idle period. Take trailer to a LP gas service center to have the system professionally purged.

Do not use a tool to open or close a LP cylinder supply valve. If supply valve does not completely stop the flow of LP gas when it is hand tightened, supply valve is defective and must be replaced. Turn off all gas appliances to stop the gas flow at the regulator. Take trailer to a LP gas service center to have cylinder supply valve replaced.

⚠ WARNING

Explosion or fire hazard.

If LP gas is detected (by smell or by the LP gas detector):

- Do not touch electrical switches.
- Extinguish flames and pilot lights.
- Shut off gas supply at LP cylinders.
- Leave the area until odor clears.

Have a qualified LP gas technician correct the source of gas leakage before using LP appliances.

Do not use a flame to locate the source of a gas leak.

5.1 TRAVELING WITH LP GAS

When traveling, be sure to check with the Department Of Transportation for permissible travel routes. Some roadways and tunnels do not allow vehicles equipped with LP gas.

5.2 USING LP GAS IN WINTER

As temperature decreases, so does the vaporization rate for LP gas. Butane cannot be used when temperature is 32° F or lower. In winter conditions, vaporization rate for LP may not be enough to allow normal gas consumption. An insufficient fuel supply will resemble a frozen regulator. Reduce gas consumption before having the regulator inspected.

Refer to following energy to temperature ratio chart. Refer to the manual provided with each appliance for BTU's required to operate appliance and the BTU's available from your fuel supply at these temperatures.

Temperature	% Of BTU's Available
20° F.....	200%
10° F.....	150%
0° F.....	100%
-5° F.....	75%
-10° F.....	50%
-15° F.....	25%
-20° F.....	12.5%
-44° F.....	0%

80% full @ 0° F = 64,400 BTU/Gal

5.3 REGULATOR

Rotate changeover knob with tab (A) toward the cylinder you want to use first. This will be the “service” cylinder and the other one will be the “reserve” cylinder. Slowly open both cylinder valves. The indicator (B) will turn bright green. The indicator will stay green as long as there is fuel coming from the service cylinder.

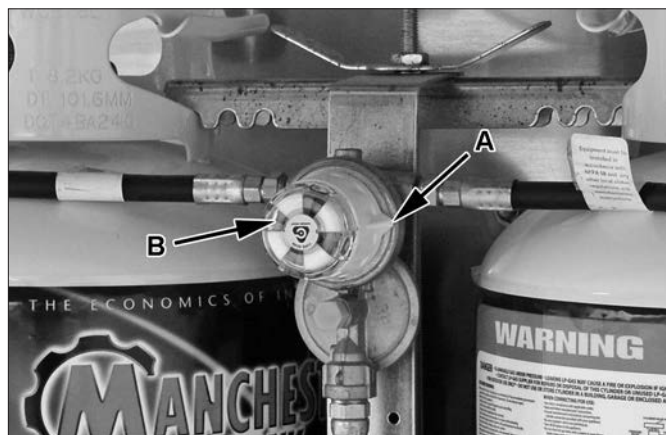

When service cylinder is empty, regulator will start drawing fuel from reserve cylinder, providing an uninterrupted supply of fuel. When regulator switches over, indicator color changes from green to red. This indicates that service cylinder is empty.

To remove empty cylinder, rotate change over lever toward reserve cylinder. Indicator will turn green and reserve cylinder then becomes service cylinder. Close valve on empty cylinder, disconnect line and remove cylinder from trailer. Have cylinder refilled by an authorized LP gas service center.

Cylinders are marked with top or an arrow to indicate correct cylinder orientation. Do not mount, store or transport cylinder in any other position. Securely install cylinders to trailer bracket after filling or replacement.

If you have regulator freezing problems, or notice moisture in the system, contact your LP gas service center.

6. ELECTRICAL SYSTEMS

Trailer electrical system is equipped with a 12 volt DC battery system and a 30 amp 120 volt, or a 50 amp 120/240 volt AC electrical system. Both systems are controlled by a power converter.

12 volt DC system consists of the house batteries, DC breakers and DC loads (lights, water pump, etc.).

120/240 volt AC system electrical system consists of a shore power cord, AC breaker panel and AC loads which may include; air conditioner, microwave, entertainment center, refrigerator (in electric mode), lights, etc.

Trailer may be equipped with a generator to power the AC loads.

Primary power is supplied via the shore power cord or the generator. This power is fed to the power converter which automatically converts a portion of the 120/240 volt AC power to 12 volt DC power. All of the accessories normally powered by the 12 volt batteries are then powered by the converter. The converter also has a charging circuit that will charge the 12 volt batteries while the trailer is connected to shore power or running the generator.

Some appliances and accessories (air conditioner, microwave, entertainment center, refrigerator (in electric mode) are only operable when power is supplied by shore power or generator.

6.1 POWER CONVERTER

Power converter supplies and controls amount of electrical current available to trailer and also provides circuit protection. Power converter has a protective thermal breaker that will disconnect AC connection if power converter overheats. This can happen if power converter is operating above its rated capacity or if power converter cooling vent is blocked.

If power converter breaker trips repeatedly, contact your dealer for assistance.

6.2 CHARGING CIRCUIT

When trailer is connected to shore power or operating the generator, trailer batteries will be charged by the power converter if battery disconnect switch is in the "ON" position.

6.3 120/240 VOLT CIRCUITS

The trailer will have an electrical panel in a cabinet or other easy access area. There is a breaker on this panel that is wired to feed power to the circuit panel in the living quarters.



Behind power converter cover is a series of circuit breakers and fuses. Circuit breakers protect AC appliances from an overload, a short in wiring or appliance itself. If an overload or a short circuit occurs, circuit breaker will trip.

If a circuit breaker trips, wait a few minutes and turn off loads on the circuit. Try resetting circuit breaker by switching it to off position and then back on. If circuit breaker continually trips with no load, leave circuit breaker off and contact a qualified electrician to inspect the circuit.

Some 120 volt outlets in trailer are GFCI type (Ground Fault Circuit Interrupter). If a GFCI circuit trips, it could be the GFCI breaker on the electrical outlet or the circuit breaker in the AC breaker panel. Check circuit breaker in AC breaker panel first and then press the "RESET" button on electrical outlet. If circuit breaker continually trips with no load, leave circuit breaker off and contact a qualified electrician to inspect the circuit.

WARNING

Fire hazard.

Improperly rated fuses and circuit breakers can cause an electrical circuit to overheat, resulting in a fire.

Replace fuses and circuit breakers with like rating.

6.4 12 VOLT CIRCUITS

12 volt master disconnect switch (A) is located on the side of the battery box is the on/off switch for the 12 volt circuits. This switch must be in the “ON” position to use any 12 volt load.

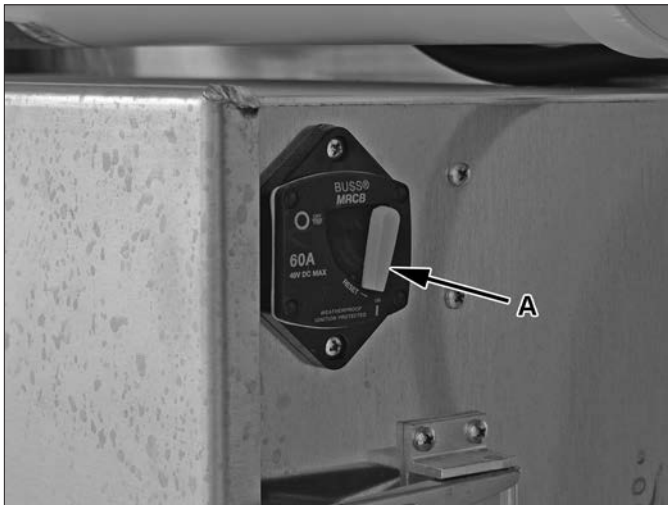

There are several replaceable blade type automotive fuses on the circuit panel. There is a circuit breaker that powers the 12 volt panel. Check this breaker if all 12 volt circuits are out.

If a 12 volt circuit fails, check fuse. A blown fuse is identified by a visible broken connection inside the fuse. Replace a blown fuse with a fuse of the same rated amperage. A higher amperage fuse could cause the wiring in that circuit to overheat, creating a fire hazard.

Before replacing a blown fuse, turn off loads on the circuit. If the fuse blows again with the loads turned off, leave the fuse for that circuit out and contact an qualified electrician to inspect the circuit.

⚠ WARNING

Fire hazard.

Improperly rated fuses and circuit breakers can cause an electrical circuit to overheat, resulting in a fire.

Replace fuses and circuit breakers with like rating.

6.5 SHORE POWER

⚠ WARNING

Explosion or fire hazard.

Always use cord that was supplied with trailer when manufactured or a Featherlite approved replacement. Never use an extension cord.

Always connect electrical cord to a grounded source of shore power.

Never remove prongs from shore power plug.

Connect only to source of proper voltage.

6.5.1 CONNECT SHORE POWER

The trailer can be equipped with either a 50 amp shore power cord or a 30 amp shore power cord.



50 Amp



30 Amp

The options and electrical loads in trailer determine which shore power cord was installed. Do not use adapters or extension cords. If the shore power source is not equipped for your shore power cord, move to another location or if outdoors, use the generator.

1. Open access door connect shore power cord connector to trailer connector. Push in and turn connector (A) clockwise to lock.
2. Connect power cord to proper power source.



- While trailer is powered by shore power, 12 volt master disconnect switch (B) located on the side of the battery box must be in the "ON" position to use a 12 volt load and also to allow house batteries to charge. It is important that disconnect switch be ON to allow batteries to recharge.

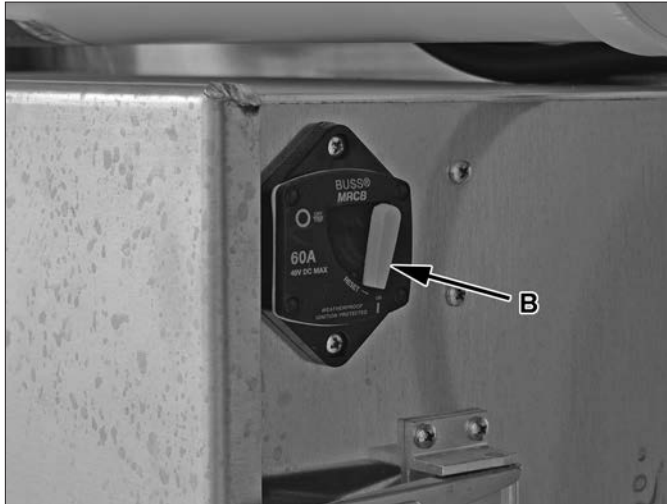

6.5.2 DISCONNECT SHORE POWER

- Turn off all electrical devices.
- Disconnect power cord from electrical power source.
- Turn connector (A) counter clockwise.
- Pull connector out and close access door. Stow power cord.

6.6 GENERATOR

⚠ DANGER

You can die or be brain damaged by carbon monoxide.

Do not operate gas appliances or generator without a working carbon monoxide detector.

Test carbon monoxide detector for operation before operating any gas appliances or generator.

⚠ WARNING

Operating a gasoline or diesel generator can lead to death or serious injury by:

- Carbon Monoxide
- Fire and Explosion
- Electrocutation

Have a working carbon monoxide detector in the living space of trailer before operating generator.

Do not refuel a running generator or refuel near ignition sources.

Generator can be started from a remote switch.

Carbon monoxide is an odorless gas that can cause death. Make sure that no exhaust from a running generator can accumulate in areas where people or animals may be present. A confined area will not allow proper ventilation and carbon monoxide fumes can enter the trailer.

Conditions that can redirect exhaust fumes are for example:

- Being drawn in by fans or ventilators operated in a trailer.
- Prevailing wind.
- Being trapped between adjacent trailers, vehicles or buildings.
- Being trapped between or in a snow bank or other materials that can redirect fumes.

Your trailer can be equipped with one of several sizes of generator.

Trailers equipped with a generator are equipped with a fully automatic transfer switch. This switch will automatically switch the power source between shore and generator.

Transfer switch will switch over to run loads off generator for as long as generator is running. It may take 1-2 minutes for the transfer switch to begin using generator power. When generator is turned off, transfer switch will switch back over to shore power, if connected.

This manual provides you with basic generator start up and shut down procedures. Refer to the Operator's Manual provided with the generator for additional safety, operation and maintenance information.

6.6.1 STARTING GENERATOR

1. Check engine oil and fuel levels. See generator Operator's Manual for oil check location and oil and fuel requirements.
2. Press and hold switch (A) in the stop position for ten seconds to prime generator engine. This switch operates an auxiliary fuel pump to pump fuel to generator engine. In some cases, generator is mounted on top of trailer and fuel tank is mounted low in a storage compartment.
3. Press and hold switch (A) in start position to start generator. Start switch has a built-in delay before generator will attempt to start. Release switch when engine starts.

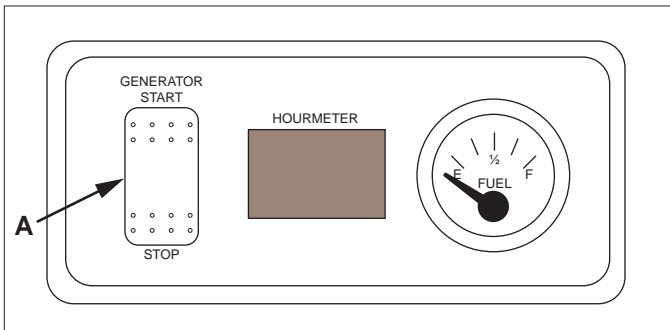

4. While trailer is powered by the generator, 12 volt master disconnect switch (B) located on side of battery box must be in the "ON" position to use a 12 volt load and also to allow batteries to charge. It is important that disconnect switch be ON to allow batteries to recharge.

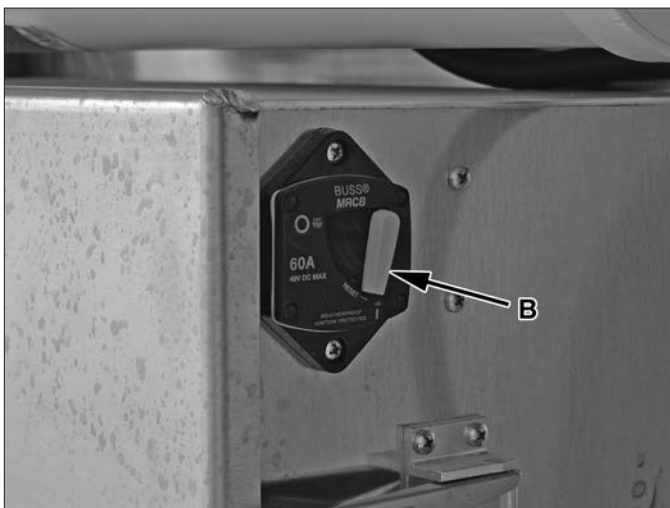

6.6.2 STOPPING GENERATOR

1. Turn off all electrical loads and allow generator to run for two minutes to cool down.
2. Press and hold switch (A) in stop position to stop generator.

7. SLIDEOUT

⚠ WARNING

Crushing hazard.

Bystanders can be crushed by the slideout.

Keep people away from the slideout while extending and retracting.

NOTICE

Prevent equipment damage.

DO NOT alter or modify the slideout or drive mechanism for any reason. Altering or modifying may cause a malfunction resulting damage to the trailer.

Service work must be performed by an authorized Featherlite technician.

NOTICE

If either side of the slideout stops moving, release control switch immediately.

First indication of slideout binding may be a loud banging noise resulting from clutch slipping.

Stop operation immediately and check for obstacles/binding.

NOTICE

Verify there is adequate clearance to fully extend slideout.

Extend Slideout

1. Press and hold bottom of switch (A) to extend slideout. Release switch to stop slideout at any time. Release switch when slideout is fully extended.

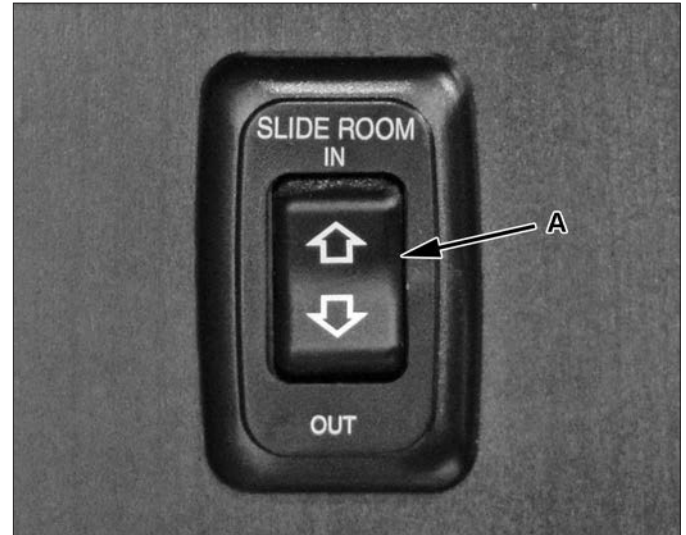

Retract Slideout

1. Press and hold top of switch (A) to retract slideout. Release switch to stop slideout at any time. Release switch when slideout is fully retracted.

Manual Operation

The shaft of slideout drive motor has been modified with an adapter to permit use of a crank handle to manually turn motor shaft and extend/retract slideout. The access hole for the crank is centered opposite the slideout in the lower frame rail. Remove crank handle immediately after use.

⚠ WARNING

Prevent injury.

Manual crank handle will spin if slideout control switch is pushed.

Remove crank handle immediately after manually extending or retracting slideout.



8. ELECTRICAL APPLIANCES

8.1 GENERAL INFORMATION

This section covers the operation of the air conditioning, exhaust hood, microwave oven and electric cook top. The refrigerator, which can operate on electric or gas, is covered in the Gas Appliances section.

8.2 AIR CONDITIONING

Trailer is equipped with a roof mounted air conditioner controlled by a central thermostat.

The air conditioning is ducted throughout the trailer.

The air conditioner can be operated while the trailer is connected to shore power or running the generator.

The air conditioner has a heating element installed to take the chill out when the air temperature is a few degrees too cool for comfort. This is used as a “chill chaser”, not as a substitute for a furnace. Use the installed furnace for heating when necessary.

Refer to the air conditioner manufacturer’s Owner’s Manual for additional safety, operating and maintenance information.

8.2.1 THERMOSTAT

1. Move thermostat switch (A) to Cool.
2. Use up or down arrows (B) to select desired temperature.
3. Set fan mode switch (C) to Auto.
4. To turn air conditioner off, move thermostat switch (A) to off.

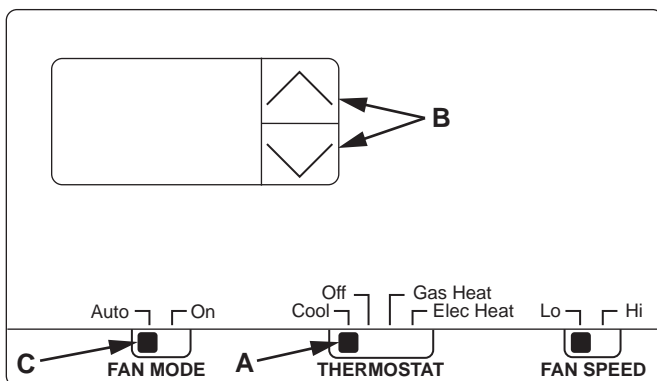

8.2.2 MAINTENANCE

Every Two Weeks

If equipped, remove cover and clean or replace air conditioning unit filter as necessary. Replace any filter that is worn, torn or deteriorated.

8.3 EXHAUST HOOD

Move exhaust hood fan switch (A) to on position while cook top is in use to exhaust odors and gas fumes to the outside. Refer to exhaust hood manufacturer’s Owner’s Manual for additional safety, operating and maintenance information.

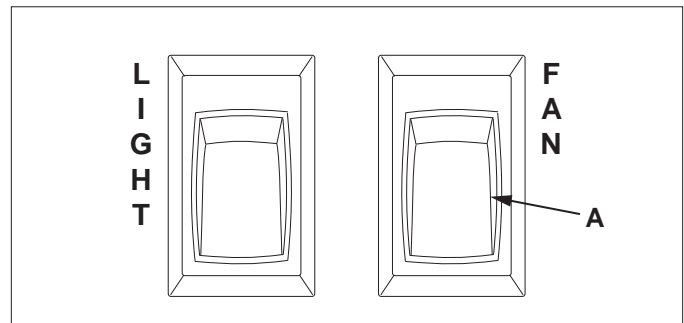

8.4 MICROWAVE OVEN

Read microwave manufacturers Owner’s Manual for safety, operating and maintenance information.

8.5 COOK TOP

Read cook top manufacturer’s Owner’s Manual for safety, operating and maintenance information.

1. Move exhaust hood fan switch (A) to on position while cook top is in use to exhaust odors to the outside.
2. Open cook top cover and rotate control knobs for desired burners to desired setting.
3. Turn all burners off after use. To turn burners off, rotate control knobs to off position.

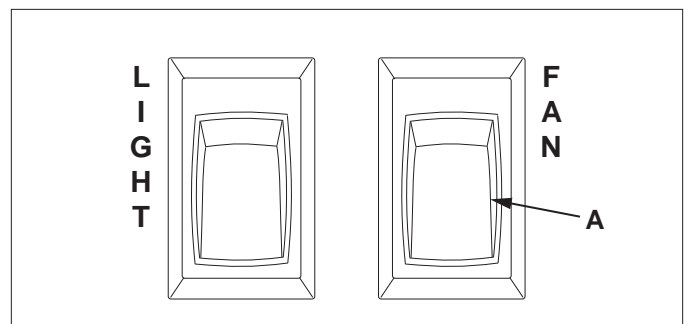

9. GAS APPLIANCES

9.1 CARBON MONOXIDE (CO) HAZARD

Carbon monoxide is a colorless, tasteless, odorless gas that can cause brain damage or death. Carbon monoxide can come from operation of fuel burning appliances such as a water heater, furnace and cook top.

Symptoms of carbon monoxide poisoning are:

- Headache
- Drowsiness
- Nausea
- Vomiting
- Shortness of breath
- Unconsciousness

If any of these symptoms exist, remove the victim immediately to fresh air and get medical attention.

Never operate a portable fuel burning appliance inside trailer. Deadly carbon monoxide is produced by these appliances. Never use a cooking appliance to provide comfort heating.

DANGER

You can die or be brain damaged by carbon monoxide.

Do not operate gas appliances or generator while trailer is in an enclosed building or confined area.

Test carbon monoxide detector for operation before operating any gas appliances or generator.

WARNING

Carbon monoxide poisoning or fire hazard.

The fumes from burning gas contain carbon monoxide, an odorless gas that can cause death or brain damage.

Cooking appliances used for comfort heating can ignite surrounding surfaces.

It is not safe to use cooking appliances for comfort heating.

Never operate any gas burning appliances while trailer is in an enclosed building or confined area. A confined area will not allow proper ventilation and carbon monoxide fumes can enter trailer.

Conditions that can redirect carbon monoxide fumes are for example:

- Being drawn in by fans or ventilators operated in a trailer.
- Prevailing wind.
- Being trapped between adjacent trailers, vehicles or buildings.
- Being trapped between or in a snow bank or other materials that can redirect fumes.

You must have a working carbon monoxide detector in the living space of the trailer.

Test carbon monoxide detector after periods of storage, before each trip, or before operating any gas burning appliance.

A blocked appliance vent can cause a fire or result in carbon monoxide entering into trailer.

Check the following appliance vents for debris after periods of storage and before each use:

- Furnace
- Water Heater
- Exhaust Hood

Turn exhaust hood on before lighting cook top burners or oven to vent fumes and cooking odors outside.

9.2 LP GAS APPLIANCE HAZARDS

Your trailer may be equipped with the following appliances that operate on LP gas:

- Cook top
- Water heater
- Refrigerator
- Furnace

Keep LP gas cylinder supply valves closed at all times, except when using a gas appliance.

LP gas system in trailer is designed to operate on LP gas only, NOT natural gas. A natural gas supply is not safe for use in an LP gas system.

⚠ WARNING

Prevent explosion or fire.

Connect LP gas system to a supply of LP gas only, NOT natural gas.

Do not place a LP gas cylinder inside trailer.

Have LP gas cylinder refilled by a qualified LP gas supplier.

Verify all LP gas appliances are off before opening LP gas cylinder supply valves. If an appliance is left on, gas could accumulate in trailer creating a fire or explosion hazard.

⚠ WARNING

Explosion hazard.

Gas can accumulate in the trailer if an appliance control is left on and the gas supply valve is opened.

Verify that all appliance controls are off before opening gas supply valve.

Do not attempt to fill LP gas cylinders yourself. Have cylinders filled by a qualified LP gas supplier.

⚠ WARNING

Fire and explosion hazard.

If LP gas is detected (by smell or LP gas detector):

- Do not touch electrical switches.
- Extinguish flames and pilot lights.
- Shut off gas supply at LP cylinders.
- Leave the area until odor clears.

Have a qualified LP gas technician correct the source of gas leakage before using LP appliances.

Do not use a flame to locate source of a gas leak.

Turn off all gas appliances and pilot lights before refueling LP gas cylinders, fuel tanks, or when towing trailer. Some

automatic ignition appliances may continue to spark after gas is turned off.

9.3 WATER HEATER

⚠ WARNING

Carbon monoxide, fire and explosion hazard.

Read and understand sections 9.1 and 9.2 before operating water heater.

Turn Water Heater On

1. Be certain switch (A) is in Off position.
2. Open supply valves on LP gas cylinders if not already open.
3. Move water heater switch (A) to On position. There will be a fifteen second purge before the electronic spark lights the burner. If the burner does not light on the first attempt, it will automatically try two more times. If the burner does not light after the third attempt, the reset light (2) will come on. Move switch (A) to Off and then On. If water heater still does not light, have the water heater inspected by an qualified technician.

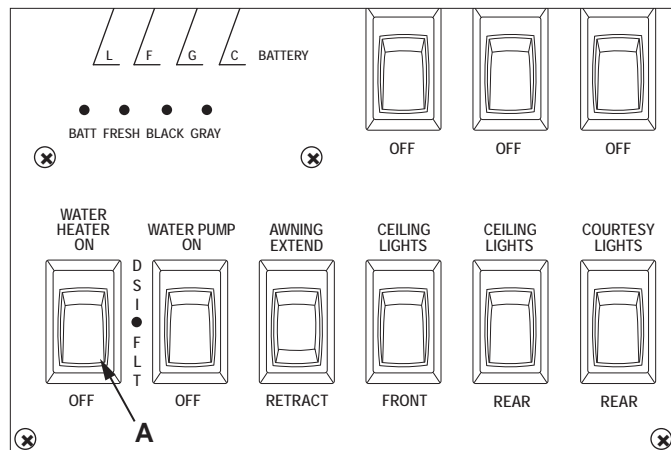

Turn Water Heater Off

1. Move water heater switch (A) to Off position.
2. Close LP gas cylinder supply valves if no other gas appliance will be used.
3. For winter storage, see Winterizing And Storage.

9.4 FURNACE

⚠ WARNING

Carbon monoxide, fire and explosion hazard.

Read and understand sections 9.1 and 9.2 before operating water heater.

The furnace is a 12 volt controlled, electronic spark ignition, LP gas furnace.

Use the instructions that follow and the manufacturers instructions for the furnace that is installed in your trailer.

1. Verify that 12 volt disconnect switch is on and open the LP gas cylinder supply valve.
1. Move thermostat switch (A) to Gas Heat.
2. Use up or down arrows (B) to select desired temperature.
3. Set fan mode switch (C) to Auto.
4. To turn furnace off, move thermostat switch (A) to off.

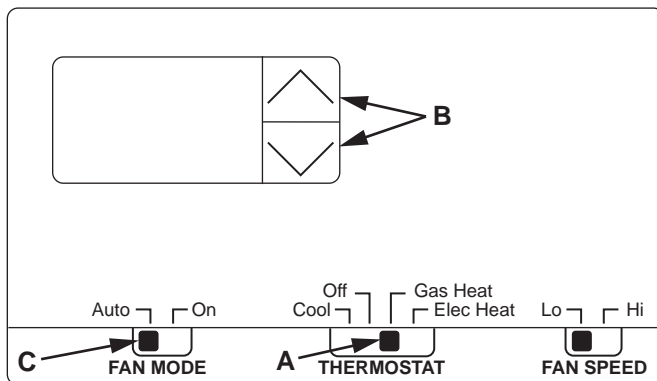

9.5 Cook Top

⚠ WARNING

Carbon monoxide, fire and explosion hazard.

Read and understand sections 9.1 and 9.2 before operating water heater.

Use the instructions that follow and the manufacturers instructions for the cook top that is installed in your trailer.

Turn exhaust hood on and open a window while the cook top is in use to exhaust gas vapors and cooking odors.

⚠ WARNING

Fire and explosion hazard.

Attempting to light more than one burner at a time can cause excess gas to accumulate.

Light one burner at a time.

⚠ WARNING

Burn hazard.

Do not touch any of the following items while cook top is in use, and after use until these items have had sufficient time to cool:

- Burners
- Burner grates
- Areas near burners

Lighting Burners With Match or Spark Device

1. Turn exhaust hood on and open a window.
2. Verify that LP gas supply is turned on. Rotate desired burner control (A) to Lite.
3. Immediately light burner with a match or a spark igniter designed for this purpose by holding it near burner port (B).
4. Extinguish match or spark igniter and adjust flame as necessary.
5. To extinguish burner flame, turn burner control clockwise to Off position.

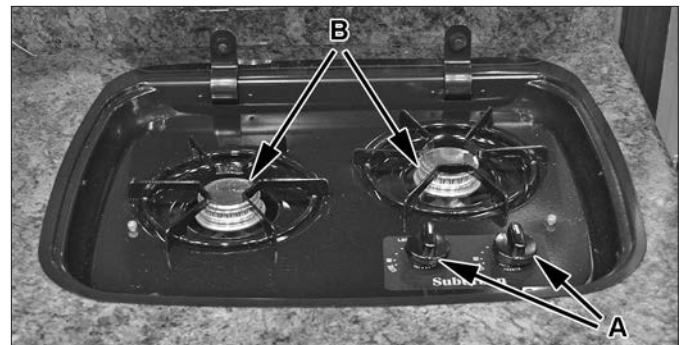



9.6 REFRIGERATOR

⚠ WARNING

Carbon monoxide, fire and explosion hazard.

Read and understand sections 9.1 and 9.2 before operating water heater.

Use the instructions that follow and the manufacturers instructions for the cook top that is installed in your trailer.

There are two sizes of standard refrigerators available, 2.7 cu. ft. and 6.0 cu. ft.

Both sizes are available as two-way (120 volt or LP) refrigerators. Various sizes may be used in custom applications.

Use the instructions that follow and the manufacturers instructions for the refrigerator that is installed in your trailer.

6.0 Cu. Ft. Refrigerator

1. Press On/Off button (A) to turn refrigerator on.
2. The Mode button (B) allows you to select between auto, manual electric or manual gas modes. In Auto mode, refrigerator will select the most efficient power source available. The first choice is 120 volts AC, then LP gas. In graphic below, Auto mode is selected.

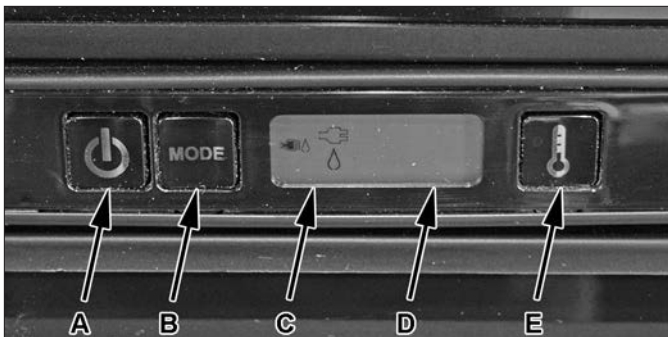

Selected operating mode is displayed in area (C).

In manual electric mode, refrigerator cools using AC power only.

In manual gas mode, refrigerator cools using LP gas only.
Current refrigerator setpoint is displayed in area (D).

To change temperature setpoint, press and hold button (E) to scroll through settings or press and release button (E) to change setpoint on number.

Temperature setpoints are displayed as numbers 1-9. 1 is warmest and 9 is coldest setting.

10. INTERIOR FURNISHINGS

10.1 ROOF VENT

The bathroom equipped with a 12 volt combination roof vent and fan.

1. Press top of roof vent switch (A) to open roof vent.
2. Press top of fan switch (B) to turn fan on. Turn fan off before closing roof vent.

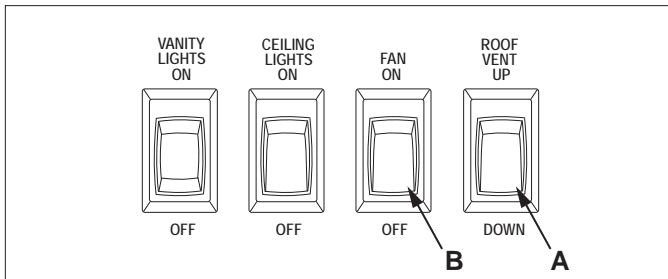

10.2 SOFA/BED CONVERSION

Convert Sofa To Bed

1. Remove table and post if equipped.
2. Pull front edge of seat upward and outward while gently pushing downward on backrest.



Convert Bed To Sofa

1. Lift front edge of seat and push toward wall while gently lifting upward on backrest.
2. Continue pushing front edge of seat until the sofa is fully seated against wall.
3. Install post and table if equipped.

10.3 DINETTE/BED CONVERSION

Convert Dinette To Bed

1. Remove dinette cushions, raise table and release catch on table leg brace and fold the leg against bottom of table.
2. Pivot table onto supports attached to dinette seats.
3. Lay dinette cushions across table to form bed.

Convert Bed To Dinette

1. Remove cushions and lift table off supports and pivot upward.
2. Release leg from bottom of table. Pivot leg away from table and lock in position 90° to table.
3. Lower table until table leg is on floor.
4. Position dinette cushions.

11. AWNING

NOTICE

Prevent equipment damage.

Do not open awning if the possibility of wind in excess of 20 mph exists. Awning, awning supports and/or trailer can be damaged by wind.

Verify there is adequate clearance to fully extend awning.

1. Verify door is not in path of awning arms.
2. Press and hold top of awning button (A) to extend awning.

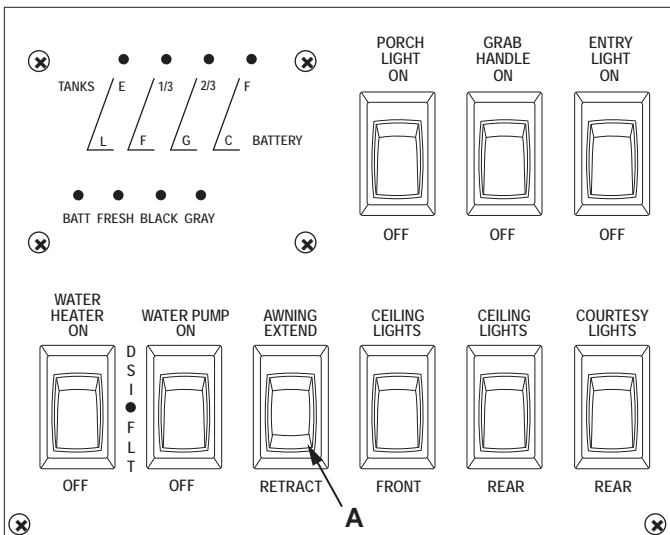

3. Release switch when awning is fully extended.

The awning has shocks to absorb a slight wind. These shocks will partially retract if water builds up on the awning, allowing the water to drain off of the awning.



4. Press and hold bottom of awning switch (A) to retract awning.
5. Release switch when awning is fully retracted.

12. STORAGE AND WINTERIZING

12.1 PREPARING TRAILER FOR STORAGE

Properly preparing your trailer for storage will greatly reduce the possibility of damage to the trailer. Use the following steps when preparing your trailer for storage. If the trailer will be subjected to temperatures at or below 32° F while in storage, follow the steps under “Winterizing” also to protect the trailer water system.

1. Remove all perishable items from trailer and refrigerator.
2. Turn off water heater, refrigerator, furnace and gas supply valves.
3. Clean refrigerator and prop refrigerator door open. Place an open box of baking soda in refrigerator.
4. Drain water heater, water lines, fresh water tank and waste tanks as instructed in section 4.
5. Drain toilet by holding flush lever down until all water is drained from toilet.
6. Remove water supply line from toilet valve.
7. Drain water from supply line and reconnect to toilet.
8. Have trailer chassis lubricated and serviced by a qualified technician.
9. Wash and wax trailer exterior.
10. Inspect all weather seals and exterior panel seams for damage. Contact your Featherlite dealer concerning seal replacement and/or repairing an exterior panel seam.
11. Close all windows and roof vents.
12. Seal off appliance vent openings to prevent rodent and insect entry.
13. Disconnect shoreline and house battery. Check with battery manufacturer for proper storage and charging procedures.
14. Check with generator manufacturer for proper storage procedures on generator.

12.2 WINTERIZING

Winterize By Draining And Blowing Out Water Lines

NOTICE

Prevent equipment damage.

Water system must be drained and winterized to avoid damage to the tanks, pump, lines and water heater.

1. Drain waste tanks as instructed in section 4.8, close drain valves and disconnect drain hose.
2. Be certain potable water tank is at least half full and demand water pump is turned on.
3. Add 7-10 gallons of water to black (sewage) holding tank by holding toilet flush lever open.
4. Add 7-10 gallons water to gray (sink and shower water) holding tank by running sink or shower faucets.
5. Drive truck and trailer to loosen and rinse material from sides of waste tanks.
6. Drain black waste tank first and then gray waste tank as instructed in section 4. Close drain valves and rinse waste drain hose.
7. Level trailer and block wheels.
8. Open valve (A) to drain potable water tank. Close valve after draining.

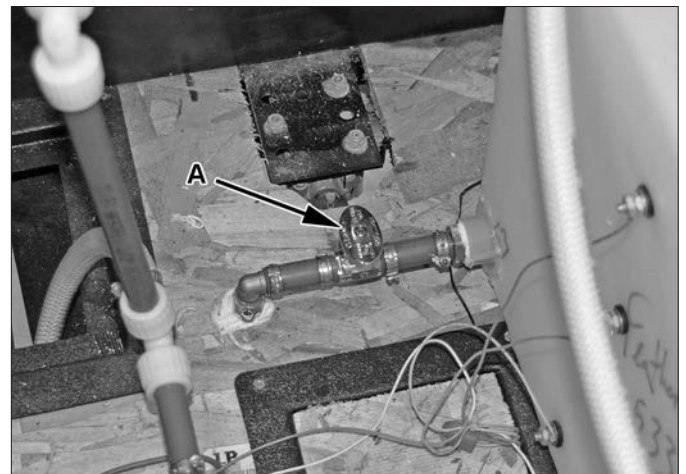

9. Be certain demand water pump is on. Open all faucets and operate toilet until water stops flowing from each faucet and toilet. Leave faucets open and turn demand water pump off.

NOTICE

Prevent equipment damage.

Do not use more than 30 psi of air pressure to blow out water system lines.

Enter air into water system lines slowly.

- Use a hand pump or a pressurized air system regulated to 30 psi or less to force the remaining water from the lines. Fabricate a blowout plug and insert in city water connection fitting (B).



- Open low point drain line valves (C).

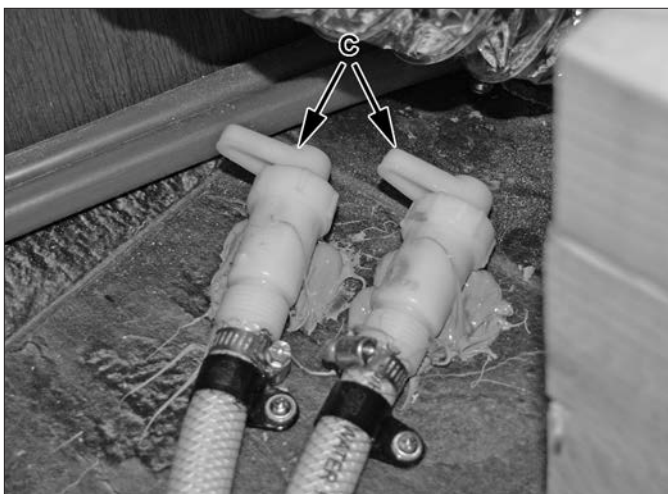

- Enter air into water system lines slowly until all water is removed from lines.
- Operate and hold toilet flush lever until water is drained from toilet.

- Turn air pressure off, disconnect blowout plug. Install cap on water connection.
- Pour one cup of recreational vehicle antifreeze into each drain to prevent holding tank odors from entering trailer.
- Place a bucket below waste tank drain spout and drain any water collected from blowing out lines.
- Close low point drain line valves (C).

Winterizing By Draining And Adding Antifreeze To Water Lines

NOTICE

Prevent equipment damage.

Water system must be drained and winterized to avoid damage to the tanks, pump, lines and water heater.

- Drain waste tanks as instructed in section 4, close drain valves and disconnect drain hose.
- Be certain potable water tank is at least half full and demand water pump is turned on.
- Add 7-10 gallons of water to black (sewage) holding tank by holding toilet flush lever open.
- Add 7-10 gallons water to gray (sink and shower water) holding tank by running sink or shower faucets.
- Drive truck and trailer to loosen and rinse material from sides of waste tanks.
- Drain black waste tank first and then gray waste tank as instructed in section 4. Close drain valves and rinse waste drain hose.
- Open low point drain line valves. Close after all water is drained.
- Level trailer and block wheels.

9. Turn water pump switch (A) off.
10. Turn water heater switch (B) off.

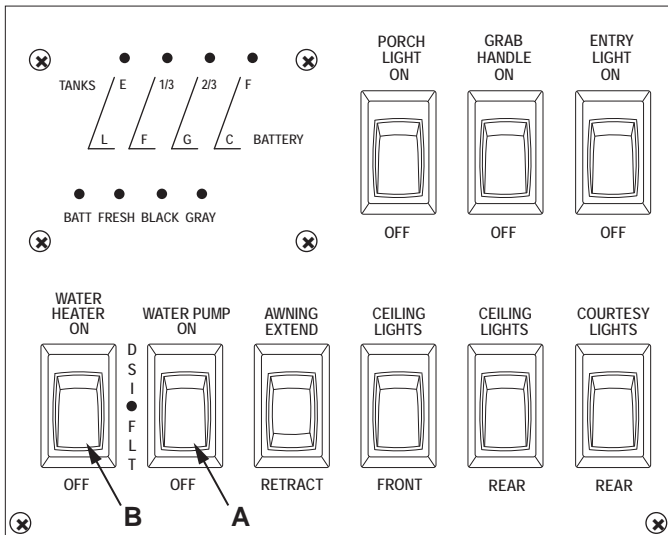

11. Open valve (C) to drain potable water tank. Close valve after draining.

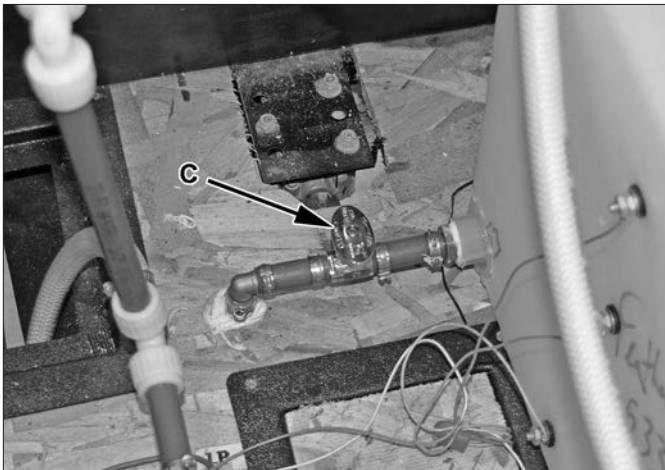

12. Drain water heater and close valve.
13. Be certain all valves are closed.
14. Remove cap (E) from main suction line and install suction line (F) from winterizing kit provided with trailer.
15. Place other end of suction line into container of recreational vehicle antifreeze. Move valve (G) ¼ turn to allow pump to siphon from antifreeze bottle. System will require 2-3 gallons to properly winterize.

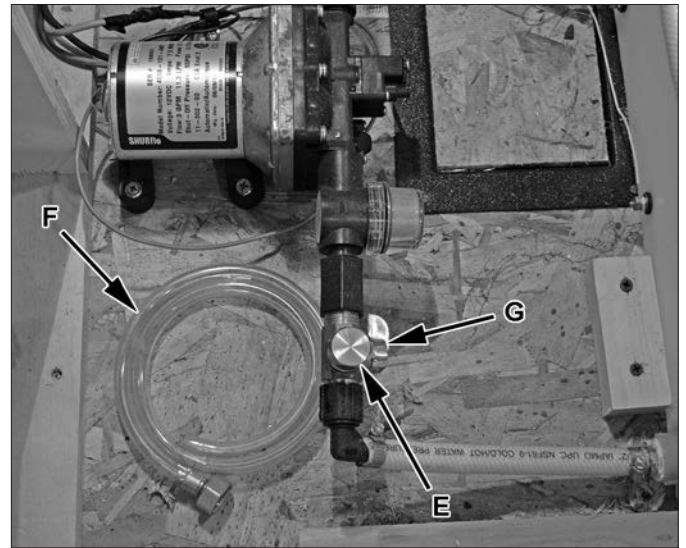

16. Turn demand pump switch on.
17. Open bypass valve (H) on water heater to allow antifreeze to bypass water heater.

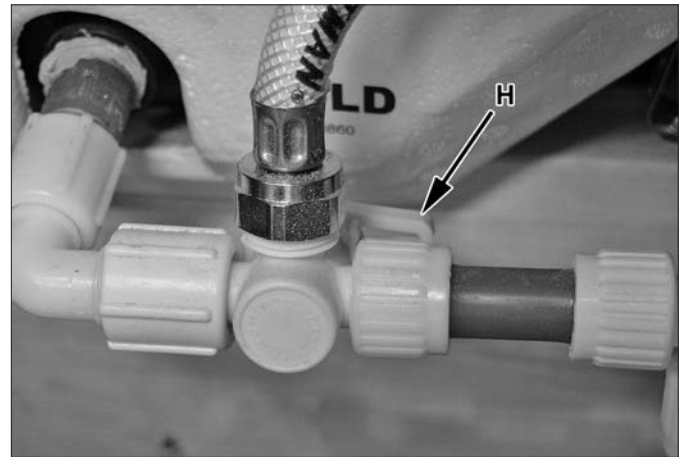

18. Open each faucet until antifreeze fills all lines.
19. Flush toilet to fill toilet and lines with antifreeze.
20. Replace cap in main suction line.



13. INTERIOR CARE

13.1 CARPET

Periodically vacuum carpet to prevent buildup of dust and dirt, and also to lengthen life of carpet.

If carpet receives a stain, immediately treat it before it gets set in. Use carpet cleaners available for household use. If you have a question on suggested care, contact a carpet dealer or a professional carpet cleaner.

To minimize fading, keep shades and curtains closed while trailer is not in use.

13.2 UPHOLSTERY

Periodically vacuum upholstery to prevent buildup of dust and dirt, and also to lengthen life of upholstery.

Upholstery may contain fire retardant and fade resistant additives that can be damaged by the use of improper cleansers. Try a cleanser in an inconspicuous area before applying it to other areas.

To minimize fading, keep shades and curtains closed while trailer is not in use.

13.3 VINYL

Clean with a soap and water solution and a damp cloth or sponge. Do not use solvents as they may damage the vinyl surface.

13.4 CABINETS

Clean with a soft cloth and a quality wood cleaning product. Do not use solvents as they may damage the surface.

Clean simulated wood, stripping and laminated cabinets with a soap and water solution and a damp cloth or sponge. Do not use solvents as they may damage the surface.

13.5 TABLES AND COUNTER TOPS

Clean tables and counter tops with cleaners available for household use.

13.6 STAINLESS STEEL SINK

Clean sink with a mild abrasive approved for stainless steel sink use. Move cleaning pad in the direction of the polish lines, rinse and apply a cleaning wax to protect finish.

13.7 BATHROOM

Refer to manufacturers Owner's Manuals for proper care of bathroom appliances.

14. MAINTENANCE AND INSPECTIONS

Perform the following inspections and service to the accessories in trailer to ensure safe and reliable operation.

Before Each Trip Or Weekly	
Accessory	Maintenance Or Inspection
Carbon Monoxide Detector.	Test operation.
LP Gas Detector.	Test operation.
Smoke Detector.	Test operation.
Fire Extinguisher.	Test operation.
Gas Appliances	Check vents for debris.

Every Two Weeks	
Accessory	Maintenance Or Inspection
Air Conditioning Filter.	Clean or replace filter.

After Periods Of Storage	
Accessory	Maintenance Or Inspection
Carbon Monoxide Detector.	Test operation.
LP Gas Detector.	Test operation.
Smoke Detector.	Test operation.
Fire Extinguisher.	Test operation.
Potable Water Tank.	Disinfect and sanitize.
Gas Appliances.	Check vents for debris.



Featherlite Apparel **GREAT LOOKS! GREAT FEEL! GREAT PRICE!**

Call Toll Free: 800-800-1230 | Shop Online: www.featherlitewear.com

Apparel availability subject to change



Repair Parts & Accessories **LOCAL DEALERS! LOCAL SALES! LOCAL SERVICE!**

Repair Parts can be obtained from the Featherlite dealer serving your area. Call your local dealer for parts & accessories for your trailer or contact our corporate office and ask for Dealer Information.

Call Toll Free: 800.800.1230 | Web: www.fthr.com (search dealer locator)





toll free 800.800.1230 | fax 563.547.6100 | email salesinfo@fthr.com
web www.fthr.com | address Hwy. 63 & 9, PO Box 320, Cresco, IA 52136



PROUD MEMBER

FEATHERLITE MANUFACTURES:

Horse Trailers
Livestock Trailers
Open Car Haulers
Custom Interiors
Concession Trailers
Motorcycle Trailers
Snowmobile Trailers
Enclosed Car Haulers
Living Quarters Trailers
Display Trailers
Semi Livestock Trailers
Vending Trailers
Hospitality Trailers
Kitchen Trailers
Utility Trailers
Truck Beds
Transporters
Living Quarters
Dry Freight Trailers
Specialty Trailers
Drop Frame Vans